

Anritsu Advancing beyond

BERTWave™

MP2110A

 BERTWave



All In One

4ch

Sampling
Oscilloscope+
BERT



Reduce cost. Increase productivity.

A single box solution - Keeping-up with Optical Communications Developments

Optical Module Evaluation and 10G to 1.6T Multi-channel Optical Module Evaluation

MP2110A

200G × 4 channel



MP2110A

Multi-channel Optical Module, Device Manufacturing and Development

Data traffic continues growing year after year and the optical communications market is expanding rapidly with the proliferation of AI. This is driving adoption of high-speed transmission standards such as 800G and 1.6T, creating demand for test instruments capable of evaluating signals in cutting-edge 200G/lane optical modules. At the same time, there is constant pressure to cut costs for these optical modules, making improved productivity and cost reduction critical challenges.

The MP2110A is an all-in-one instrument with built-in sampling oscilloscope (Eye pattern analysis) and BERT (Bit Error Rate Tester) designed for manufacturing and development inspection of 10G to 1.6T optical modules.

It increases line productivity and cuts costs.

All In One

All-in-one 4ch sampling oscilloscope + 4ch 25G BERT
There is a built-in Clock Recovery Unit for Sampling Oscilloscope

High Speed

The high-speed sampling oscilloscope.
Measurement times are slashed by measuring four channels in parallel.
Built-in PC for Stable Operation

Low Cost

Customized test systems can be configured as necessary by combining options freely.

Low Noise

The high-sensitivity sampling oscilloscope supports accurate performance even for PAM4 signals with a closed Eye opening, and for optical signals attenuated by optical switches, etc.

NRZ/PAM4 Analysis

Easy, fast and high-sensitivity, and reliable PAM4 TDECQ Measurement

Supported Applications: Evaluation of physical-layer performance for 10G/25G/50G/100G/200G/400G/800G/1.6T optical transport modules, optical cables, and associated parts used by data centers, Core/Metro networks, mobile network

Transmission Paths: Ethernet, InfiniBand, Fibre Channel, CPRI/eCPRI, SDH/SONET, OTN

Optical Transceiver Modules: SFP, QSFP, CFP, OSFP, QSFP-DD

Cables: Active Optical Cables (AOC), Direct Attach Cables (DAC)

Devices: TOSA, ROSA, High-Speed Optical Engine, PHY, Driver ICs, CPO

800G/1.6T

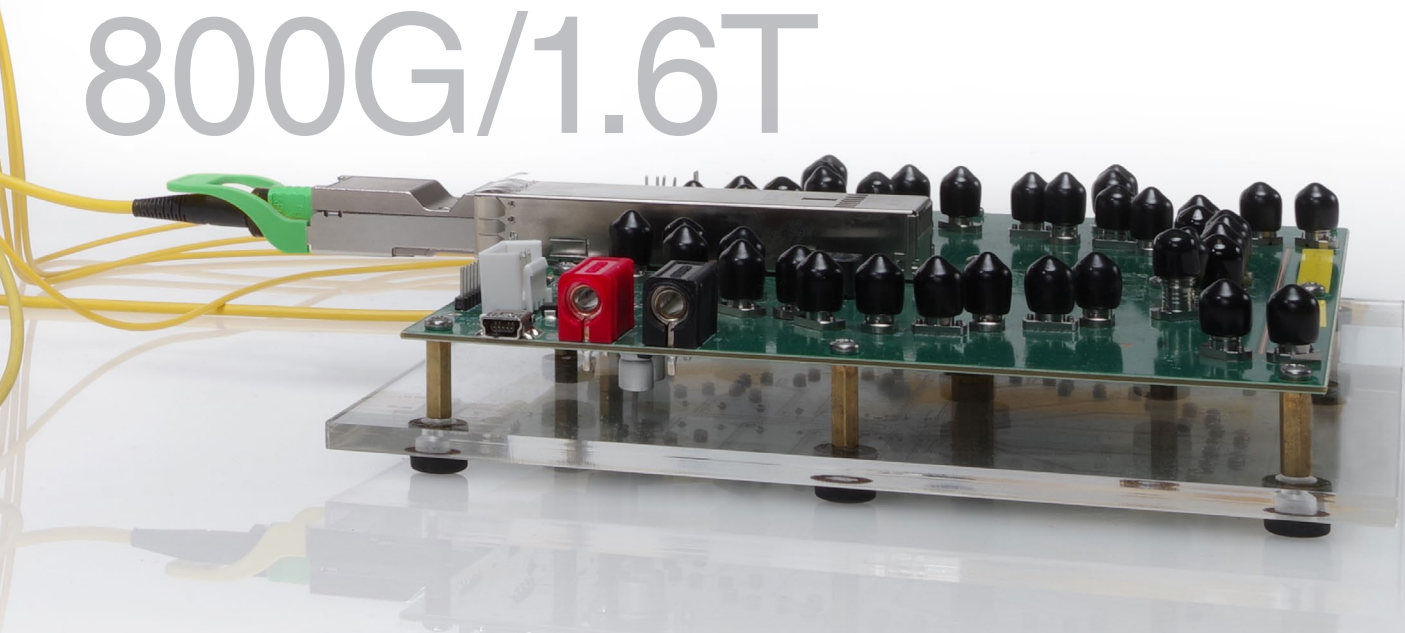

Configuring Efficient Measurement System: Integrated BERT and Sampling Oscilloscope

Previous measurement systems were extremely complex due to the need for a separate BERT as the signal source and a sampling oscilloscope for eye pattern analysis. Incorporating a BERT and 40 GHz sampling oscilloscope into the All-in-one BERTWave MP2110A greatly simplifies measurement system configuration.

Installing the BERT and sampling-oscilloscope options for up to 4ch in one unit makes it easy to implement simultaneous TRx measurements of optical modules, such as multichannel QSFP, and devices using an easily configured and controlled measurement system. This helps cut growing measurement times as the number of channels increases with development of multichannel optical modules and devices.



With a BERT and sampling oscilloscope in one box, measurement results can be captured all at once along with simultaneous Eye pattern display. As a result, all the measurement results needed to evaluate multi-channel optical modules and devices can be seen at a glance, reducing measurement times by large margins.

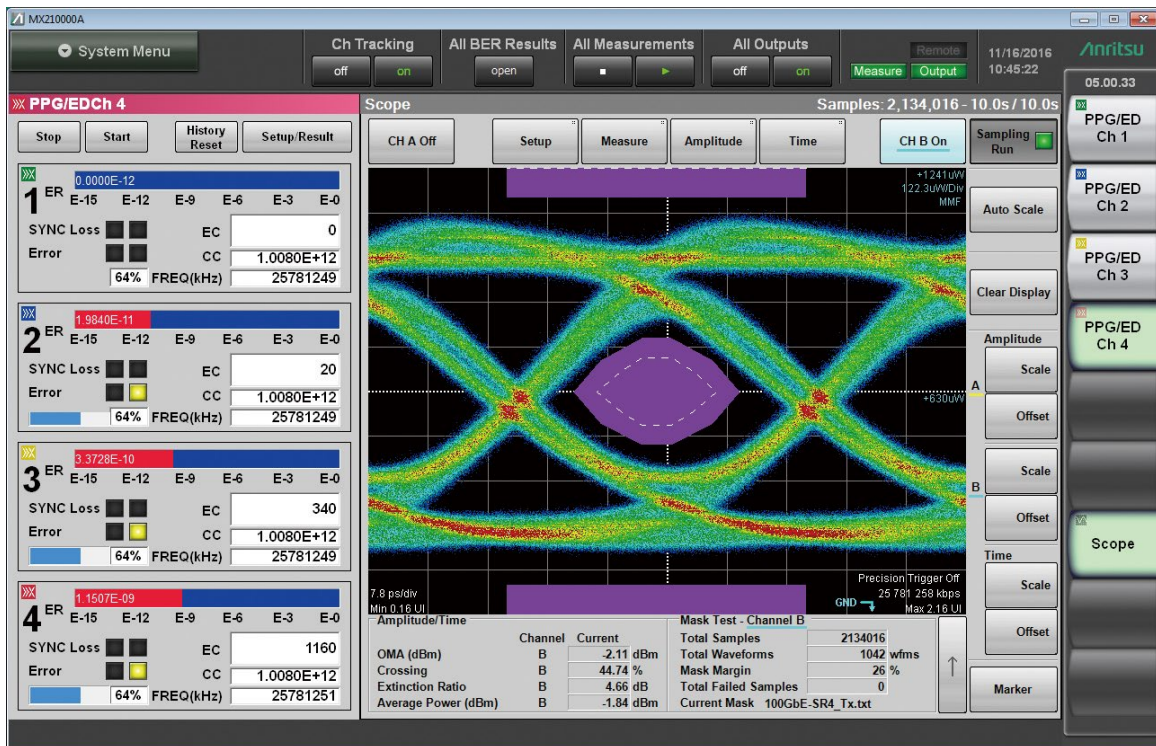

BER measurement results (left) and Eye Pattern analysis results (right) are displayed simultaneously.

Simply setting one channel of the MP2110A sets all channels simultaneously.

Operation is easy with simple settings and user interface. Remote commands are backwards-compatible with all BERTWave series, such as the MP2100B, facilitating instrument upgrades.

Configuring Efficient Measurement System: Supports both Simultaneous Measurement of All Channels and Parallel Measurement

As well as all-at-once simultaneous measurement of all channels using the sampling oscilloscope and BERT, individual channels can be measured separately. An evaluation system matching the application can be configured easily because both multichannel modules and multiple single-channel modules can be measured all at once.

Simultaneous All-Channel Measurement

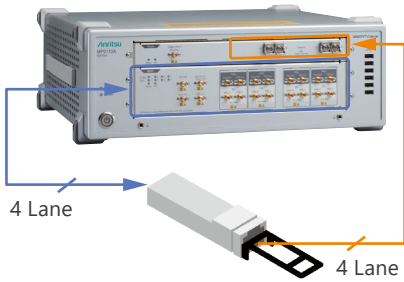

All-at-once test of quad-lane module using simultaneous measurement of all channels

Shorter test times increase throughput

Parallel-Channel Measurement

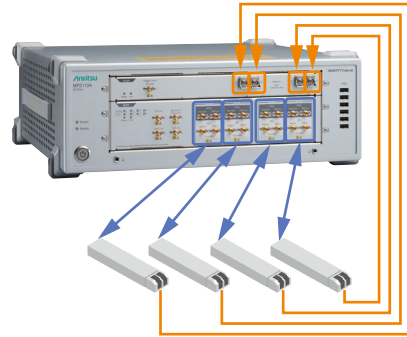

Parallel test of four single-lane modules using separate measurement of each channel

Reduced cost per channel cuts capital investment

Supports both simultaneous and parallel test methods

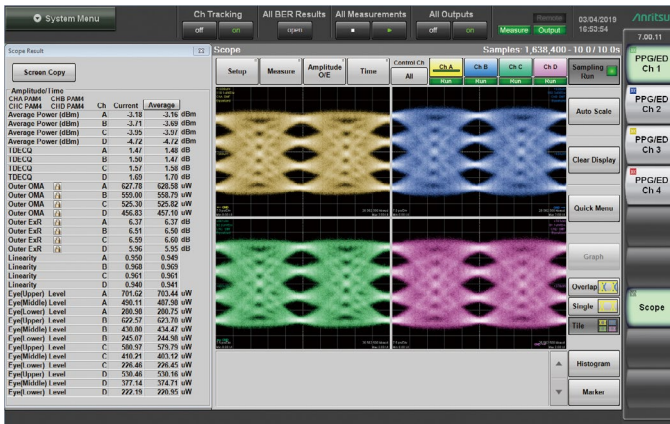

4ch PAM4 TDECQ Measurement

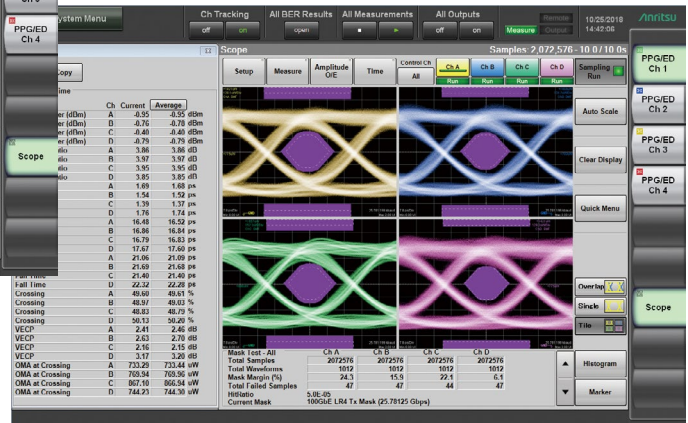

4ch NRZ Mask Margin Measurement

Supports both NRZ and PAM4

Configuring Efficient Measurement System: Built-in Clock Recovery

Accommodates Built-in NRZ/PAM4 Clock Recovery Unit (CRU)

Sampling oscilloscopes for signal waveform quality evaluation require a separate trigger clock signal synchronized with the data signal, but transmission equipment with built-in optical modules and optical modules outputting PAM4 signals sometimes do not have a trigger signal. In this case, the trigger signal is generated from the data signal using clock recovery. This optional Clock Recovery Unit (CRU) can be installed in the MP2110A Sampling Oscilloscope.

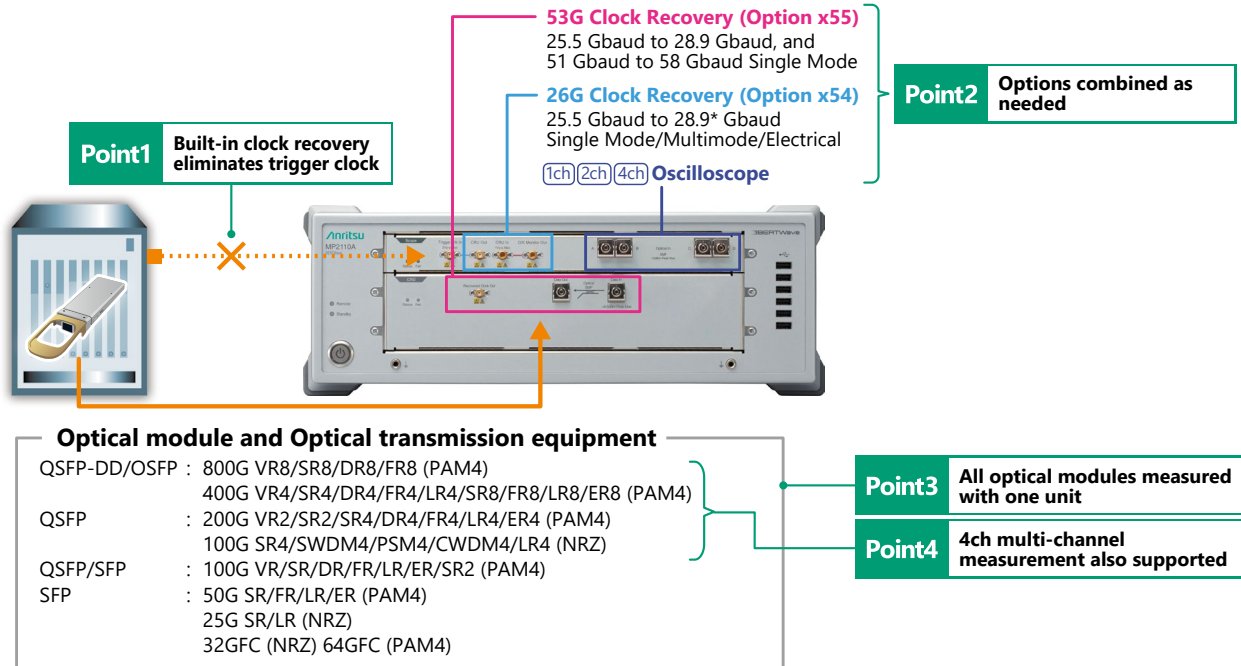

*: Requires Option x59 with Option x54 when using 28.2 Gbaud to 28.9 Gbaud.

MP2110A Optical Module Measurement Solution using Clock Recovery Options

Excellent Operability at Lower Cost

Since this clock recovery is built-in, it offers excellent operability at a lower price. The space-saving design and reduced need for complex cable connections as well as the easy-to-use settings help cut initial capital costs.

Wide Range of High-Performance Applications

The following clock recovery unit options are available:

- Option x55: Supports 25.5 Gbaud to 28.9 Gbaud & 51 Gbaud to 58 Gbaud single mode
- Option x54: Supports 25.5 Gbaud to 28.9 Gbaud single mode/multimode/electrical

These options can be combined freely to configure a flexible test system matching the site requirements at optimum cost. When all options are installed, various types of optical modules can be evaluated without a trigger clock using one MP2110A unit.

In addition, combination with a 4ch oscilloscope supports all-at-once measurement using the recovered trigger signal to help cut evaluation times for multichannel optical modules.

High Performance

When using high-sensitivity modules, the impact of insertion loss on the data waveform is minimized by optimizing internal division ratios, demonstrating its usefulness when monitoring signal waveforms requiring high sensitivity. Additionally, there is no waveform degradation due to multimode splitting because Option x54 performs signal splitting for input to the CRU and oscilloscope using electrical signals after O/E conversion.

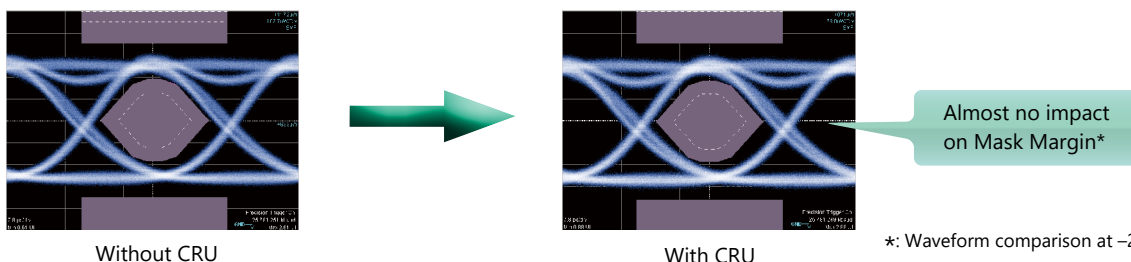

*: Waveform comparison at -2 dBm input

Fast and Stable Measurement Performance

The MP2110A support high-speed sampling at up to 250 ksamples/s. Measurement of 1 million samples at a symbol rate of 53 Gbaud requires only about 5 seconds to complete or about 7 seconds at 100 Gbaud. This cuts pattern analysis time by about 65% compared to conventional test instruments.

Additionally, the Option x8x with the Fast Sampling (Option x69) cut TDECQ analysis times by about 30%.



The MP2110A requires no external Windows PC controller, because it has a built-in PC for measurement processing. It supports high-speed processing irrespective of external PC controller specifications.

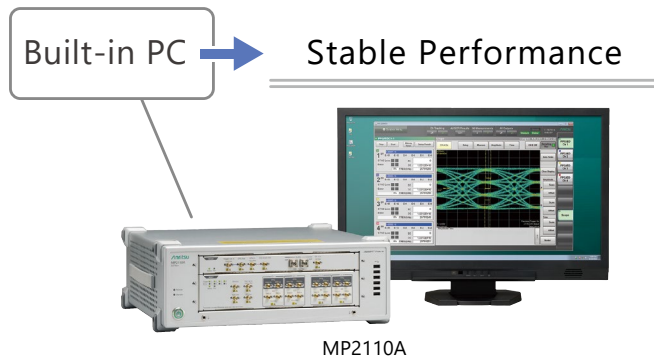

More Accurate Performance Confirmation: Sampling Oscilloscope Performance

Sampling Oscilloscope Functions

The MP2110A sampling oscilloscope has all the performance necessary for measuring optical modules such as 10G to 1.6T, and optical devices used by optical modules.

The low-noise and high-sensitivity O/E plus low-jitter trigger support more accurate measurements of narrow Eye openings of PAM4 signals as well as attenuated signals passing through optical switches, etc., helping improve production-line yields.

In comparison to conventional instruments, the wideband O/E draws accurate patterns of the characteristics of directly driven optical signals and optical modules for long-distance transmissions.

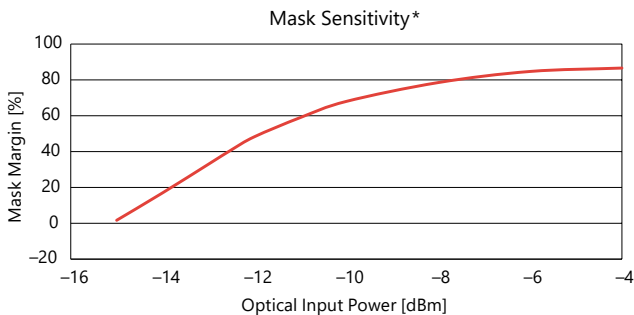

* Estimated optical power when Mask Margin (Hit Count 0) reaches 0% (calculated from optical noise)

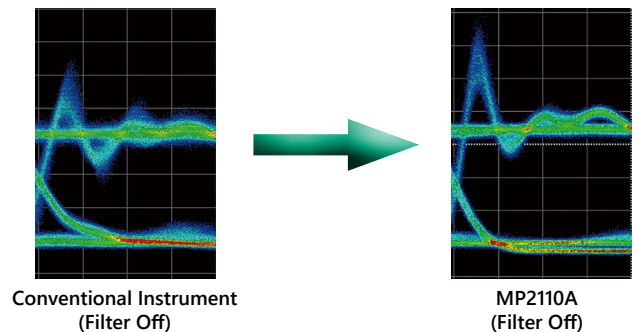

Full Range of Measurement Functions (Sampling Oscilloscope)

Sampling oscilloscope supports both NRZ and PAM4 analysis.

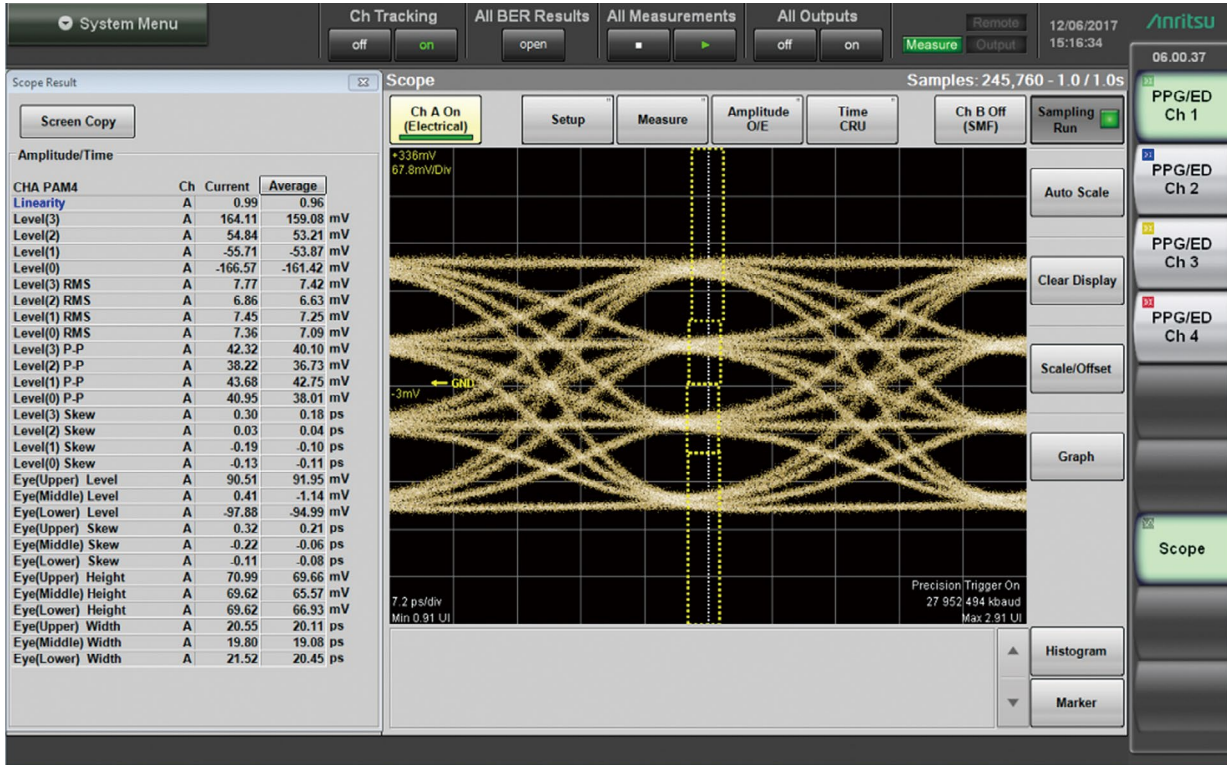

Selection of displays for up to 32 measurement items supports confirmation of multiple PAM measurement results at one screen. Additionally, all measurement results, including items not displayed on-screen, can be captured simultaneously using remote control.

NRZ

- Average Power (dBm, mW)*1
- Mask Margin (%)
- Extinction Ratio (dB)*1
- OMA (dBm, mW)*1, VMA (mV)*2
- VECP (dB)
- RIN OMA (dB/Hz)*1, *4
- TDEC (dB)*3
- One Level, Zero Level (μW, mV)*6
- Eye Amplitude, Eye Height (μW, mV)*6
- Eye Height Ratio
- Crossing (%)
- SNR
- Jitter P-P, RMS (ps)
- Rise Time, Fall Time (ps)
- Eye Width (ps)
- DCD (%)

NRZ Jitter (Option x96)

- TJ (J2, J4, J9, User Defined BER), Eye Opening (mUI)
- RJ RMS (d-d), RJ RMS (mUI)*5
- DJ (d-d) (mUI)
- PJ P-P (mUI)*5, PJ Frequency (kHz)*5
- DDJ P-P (mUI)*5, DDPWS (mUI)*5
- DCD (mUI)*5
- ISI P-P (mUI)*5

PAM4 (Option x95/x63)

- Average Power (dBm, mW)*1
- TDECQ, Partial TDECQ, Ceq (dB)
- Noise Margin, Partial Noise Margin (μW, mV)*6
- Outer Extinction Ratio (dB)*1
- Outer OMA (dBm, μW)*1, Outer VMA (mV)*2
- RIN OMA (dB/Hz)*1
- Transition Time (Rise/Fall/Slowest) (ps)
- Over/Under-shoot (%)
- Peak-to-Peak Power (dBm)*1
- Power Excursion (dBm)
- Linearity
- Levels 0/1/2/3 (μW, mV)*6
- Levels P-P, RMS 0/1/2/3 (μW, mV)*6
- Level Skews 0/1/2/3 (ps)
- Eye Levels Upper/Middle/Lower (μW, mV)*6
- Eye Heights Upper/Middle/Lower (μW, mV)*6
- Eye Widths Upper/Middle/Lower (ps)
- Eye Skews Upper/Middle/Lower (ps)

*1: Optical channel only
 *2: Electrical channel only
 *3: No IEEE-compliant 12.6-GHz hardware filter
 *4: Option x95 or Option x98/x62
 *5: Enabled when Advanced Jitter Mode
 *6: μW for optical channels and mV for electrical channels

Full Range of Measurement Functions (Sampling Oscilloscope)

NRZ Mask Margin Measurement

Testing is simple because Mask Margin tests are performed automatically. Furthermore, since the time required for Mask Margin tests is only about 1 second, line productivity is improved because standards-compliant measurements are performed at high speed in a shorter time.

- Automatic measurement within 1 second
- Real-time margin measurements
- Selectable Count and Rate at Mask Hit

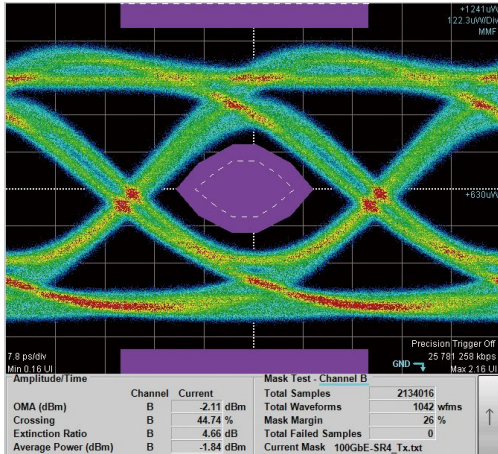

PAM4 TDECQ Measurement (Option x95/x63)

Easy capture of measurement results without complex settings. The low-noise high-sensitivity oscilloscope supports high-reproducibility measurement of even small Eye margin PAM4 signals.

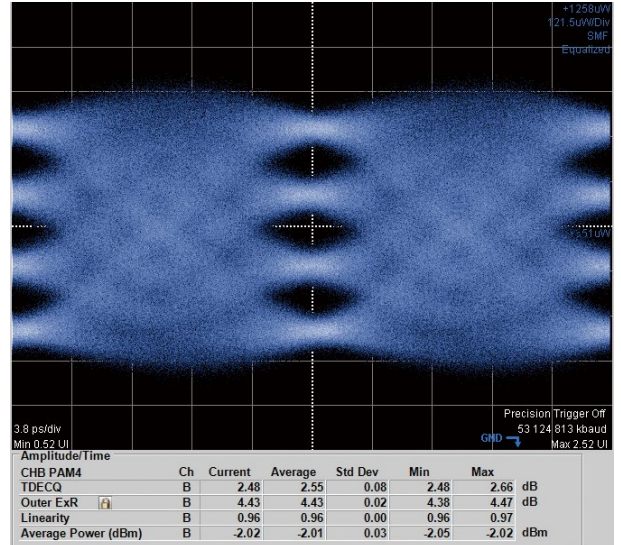

NRZ Jitter Analysis (Option x96)

This option supports separate analysis of Jitter components such as TJ, DJ, RJ, etc., with display in various graph formats.

- Fast, easy J2/J9/etc. measurements for manufacturing inspections (Eye Mode)
- Detailed analyses for DJ (Advanced Jitter Mode)
- Simultaneous Jitter Analysis and Eye Mask tests help cut measurement times

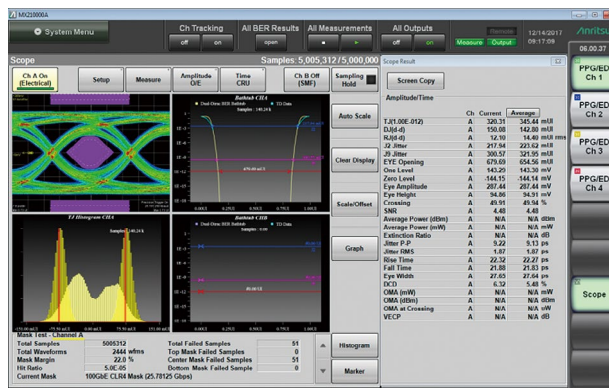
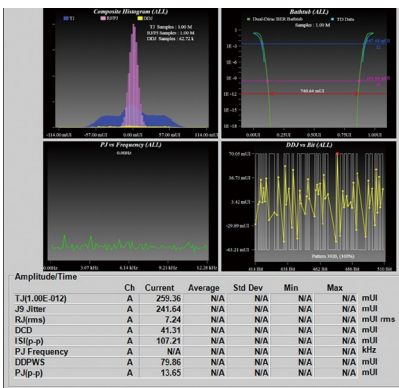

Histogram Measurement

Troubleshooting is made easier because waveform data component analysis can be performed using the mean, standard error, and scatter within the set data distribution.

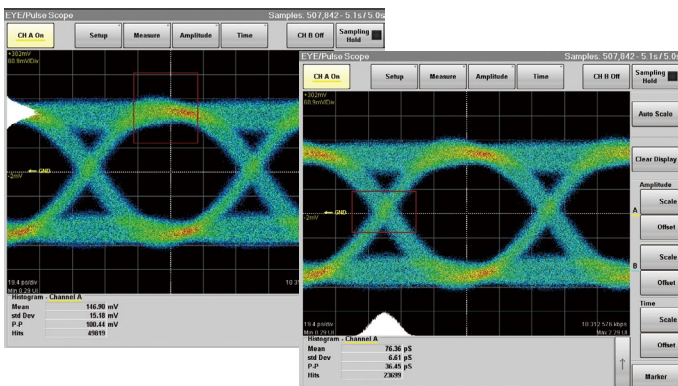

Reference Trace Function

Saving measured waveform data for reference enables comparison of current data with previous data.

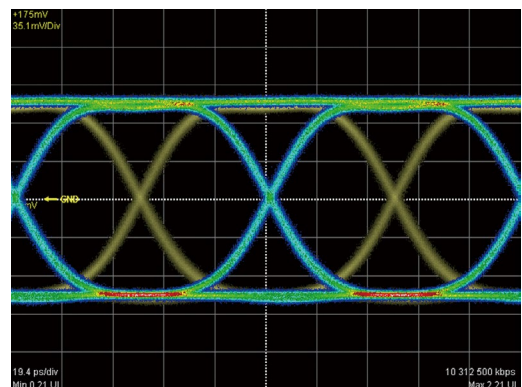

More Accurate Performance Confirmation: BERT Performance

Wideband Operation Frequency

In the standard configuration, the MP2110A BERT operates at bit rates of 24.3 Gbit/s to 28.2 Gbit/s. This range can be extended optionally to support bit rates of 9.5 Gbit/s to 14.2 Gbit/s, enabling use for various applications including 10 GbE and 100 GbE.

PPG/ED Supported Bit Rates	Application Example
24.3 Gbit/s to 28.2 Gbit/s	32G Fibre Channel, CPRI (Option 10), InfiniBand EDR, 100 GbE, 100 GbE FEC, OTU4
9.5 Gbit/s to 14.2 Gbit/s (Option x93)	InfiniBand FDR/QDR, Fibre Channel (16G, 10G, 10G FEC), 10 GbE (WAN, LAN), 40 GbE (4 × 10 Gbit/s), CPRI (Option 8, 9), OC-192/STM-64, OC-192/STM-64 FEC (G.975), OTU1e, OTU2, OTU2e

Excellent PPG/ED Performance

The MP2110A PPG has a low data jitter of 600 fs rms (typ.) for accurate measurement of the characteristics of optical modules, optical devices, etc. Additionally, the 25 mV (typ.) ED supports BER measurement of low-amplitude signals resulting from transmission path losses, helping improve DUT yields.

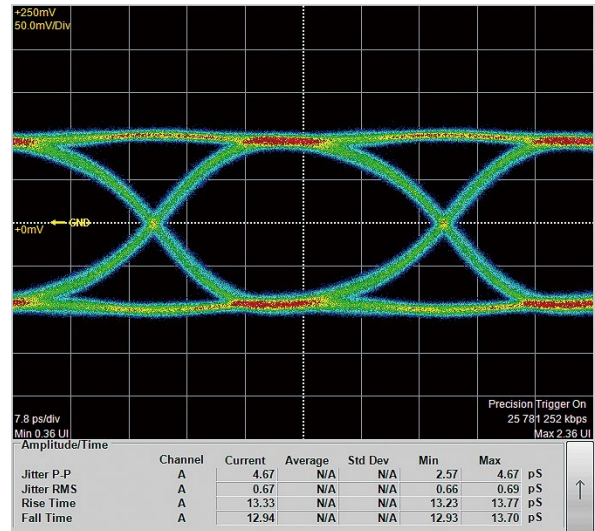

Typical PPG Waveform
25.78125 Gbit/s Electrical Loopback Waveform
(at PRBS 31, 200 mV Amplitude)

MP2110A Panel Layout

Front Panel

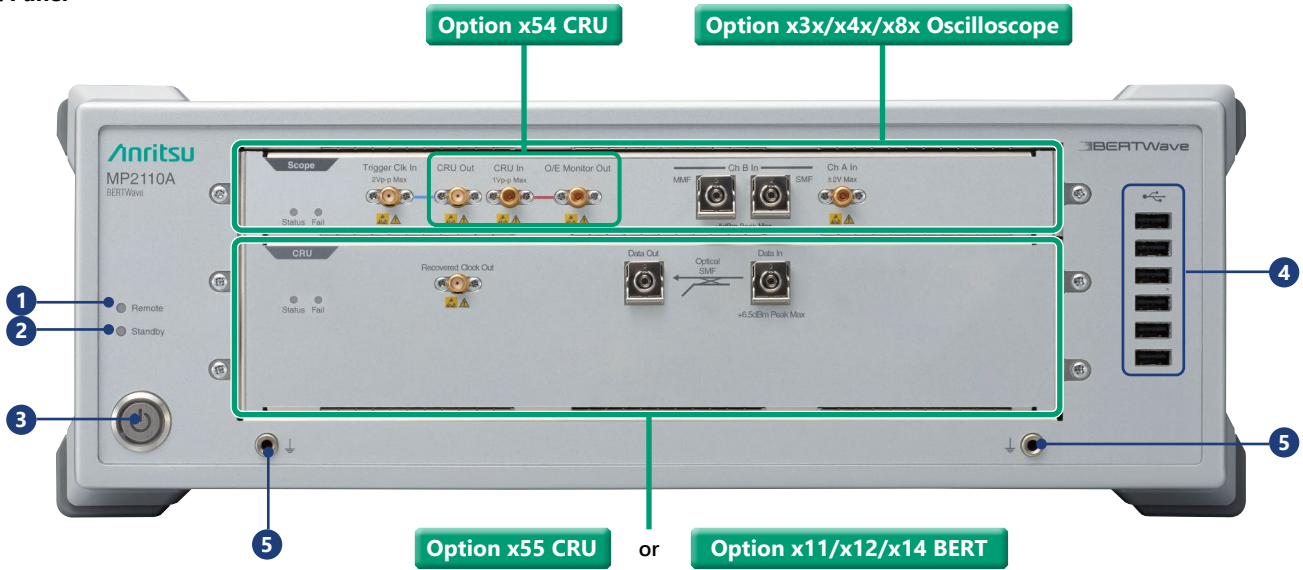

- 1 Remote Lamp**
Lit green while MP2110A under remote control.
- 2 Standby Lamp**
Lit orange while power supplied to MP2110A.
- 3 Power Switch**
Lit green while MP2110A powered-on; flashes during shutdown.

- 4 USB 2.0 × 6**
For connecting peripheral accessories, such as mouse, keyboard, etc.
- 5 Frame Ground**
For connecting wrist strap and DUT.

Back Panel

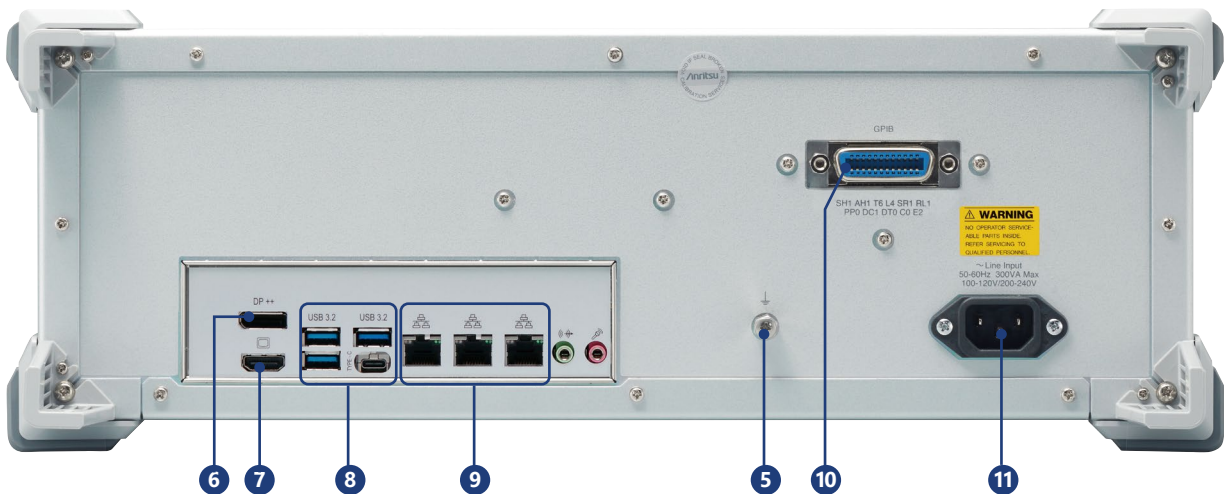

- 6 DP++**
For connecting an external monitor supporting the DisplayPort interface (passive conversion to support HDMI/ DVI output as well)*.
- 7 HDMI**
For connecting external monitor supporting HDMI specification*.
- 8 USB 3.2 × 3, USB 3.2 Type-C × 1**
For connecting a keyboard, mouse, etc. Type C supports the DisplayPort Alt mode*.

- 9 Ethernet × 3**
For connecting a PC or network to control the MP2110A remotely.
- 10 GPIB (Option x02)**
For connection to PC to remote control MP2110A.
- 11 Power Inlet**
For connecting accessory power cord.

*: Screen output requires a display with a resolution of 1280 × 800 or higher

MP2110A Panel Layout

Option x3x/x4x/x8x Oscilloscope

Option x21
(Electrical 2ch)



Option x33/x43
(25/35 GHz Optical 1ch +
Electrical 1ch)



Option x35/x45
(35 GHz Optical 1ch)



Option x36/x46
(25 GHz Optical 1ch)



Option x32/x42
(25/35 GHz Optical 2ch)



Option x30/x40
(35 GHz Optical 4ch)



Option x39/x49
(25 GHz Optical 4ch)



Option x85
(60 GHz Optical 1ch)



Option x80/x84
(60 GHz Optical 4ch)

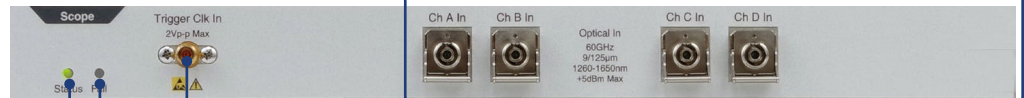

12 13

14

15

12 Status Lamp

Lit when remote command received at normal operation. Color indicates Trigger Clock input status.

Green: Trigger Clock detected normally

Red: No trigger Clock detected — check signal input at Trigger Clock Input connector

Orange: Incorrect trigger clock input frequency setting

13 Fail Lamp

Lit red when hardware fault detected.

This may light briefly at power-on, but there is no abnormality.

14 Trigger Clock Input Connector (x2x/x3x/x4x are SMA, x8x is K)

For trigger input.

15 Channel A/B/C/D Input (K or FC)

This is the oscilloscope signal input. The connector type differs depending on the option. The electrical channel uses a K-connector. Connectors for the 25 GHz optical channels are marked "MMF", and connectors for the 35 GHz optical channels are marked "SMF". Select either 25 GHz or 35 GHz when using the 25/35 GHz channels.

MP2110A Panel Layout

Option x54 CRU



16 Clock Recovery Unit Output (SMA)
Connect the standard accessory U-link coaxial cable (SMA) to the Trigger Clk In connector for use.

17 Clock Recovery Unit Input (K)

18 O/E Monitor Output (K) (Optical channel installed)*
Connect the standard accessory U-link coaxial cable (K) to the CRU In connector for use*.

*: Fit the accessory Terminator (J1632A) when not connected.
The signal cannot be monitored correctly without termination.

Option x55 CRU

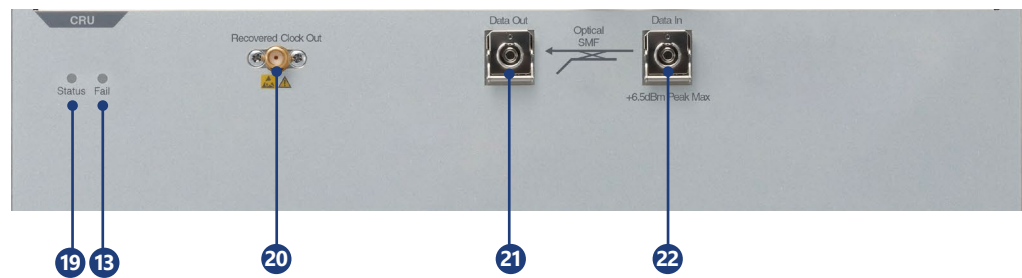

19 Status Lamp
Lit when receiving remote commands at normal start operation. Color indicates clock recovery lock status.
Green: Locked
Red: Unlocked (no signal input)
Orange: Unlocked (incorrect rate setting)

20 Recovered Clock Output (SMA)
Clock Recovery Unit output. Connected to Trigger Clk In.

21 Data Output (FC)
Branch data input signal output. Connected to oscilloscope SMF optical signal input (Ch A/B/C/D In).

22 Data Input (FC)
SM Optical Data signal input

Option x11/x12/x14 BERT



23 Output Lamp
Lit green during signal output from PPG connector.

24 Error Lamp
Lit orange at following condition at ED.
• Unable to synchronize pattern (Sync Loss)
• Bit error detected

25 Status Lamp
Lit green when receiving remote commands at normal start operation

26 Clock Output Connector (SMA)
Outputs divided clock.

27 Sync Clock Output Connector (SMA)
Outputs PPG Sync clock.
Outputs PPG Sync clock (inverted)*.

28 External Clock Input Connector (SMA)
For input of external clock.

29 PPG Output*/ED Input Connector (K)
Photograph shows configuration with Option x14 (4ch) installed; Option x11 adds 1ch and Option x12 adds 2ch.

*: Fit the accessory Terminator (J1632A) when not connected.

Application Examples

Multi-channel Optical Module Evaluation

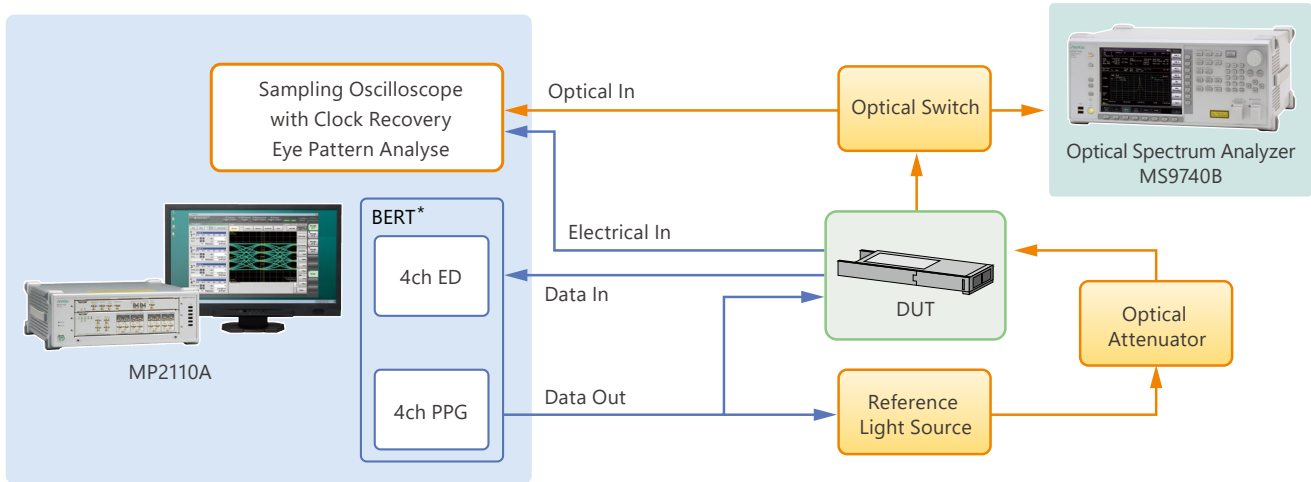

Required Test Items

- Rx Electrical Signal Eye Pattern Analysis (NRZ: Mask Margin, Jitter, Tr/Tf, etc.)
- Tx Optical Signal Eye Pattern Analysis (Optical Power, NRZ: Mask Margin, Jitter, Tr/Tf, Extinction Ratio, PAM4: TDECQ, Outer OMA/Extinction Ratio, Linearity etc.)
- Rx Signal Rx Sensitivity Test (BER Measurement)

TOSA/ROSA Evaluation

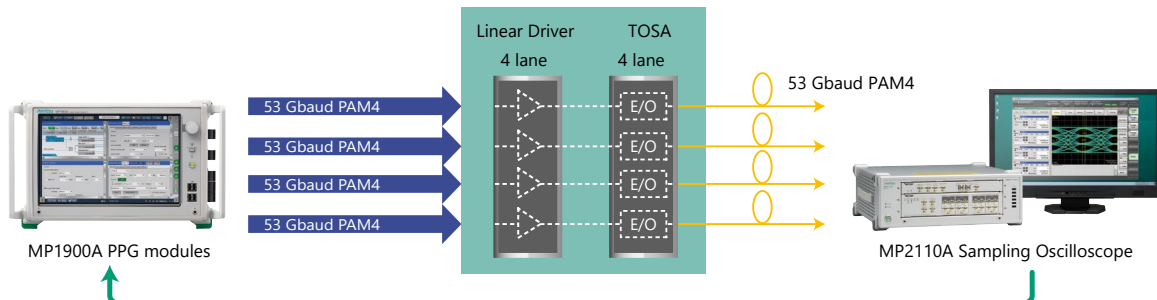
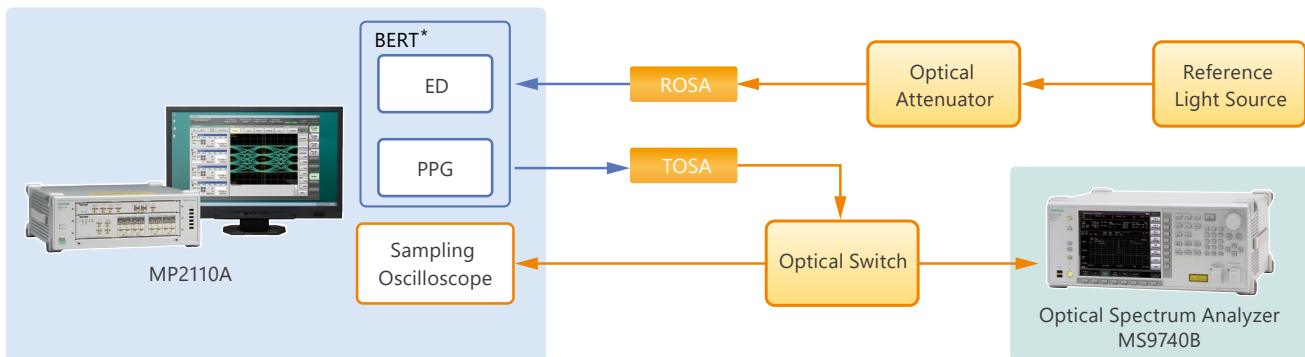

PPG Emphasis adjusted automatically when MP2110A oscilloscope connected

Required Test Items

- Tx Optical Signal Eye Pattern Analysis (Optical Power, NRZ: Mask Margin, Jitter, Tr/Tf, Extinction Ratio, PAM4: TDECQ, Outer OMA/Extinction Ratio, Linearity etc.)
- Rx Signal Rx Sensitivity Test (BER Measurement)

Application Examples

Active Optical Cables (AOC)/Direct Attach Cables (DAC) Evaluation

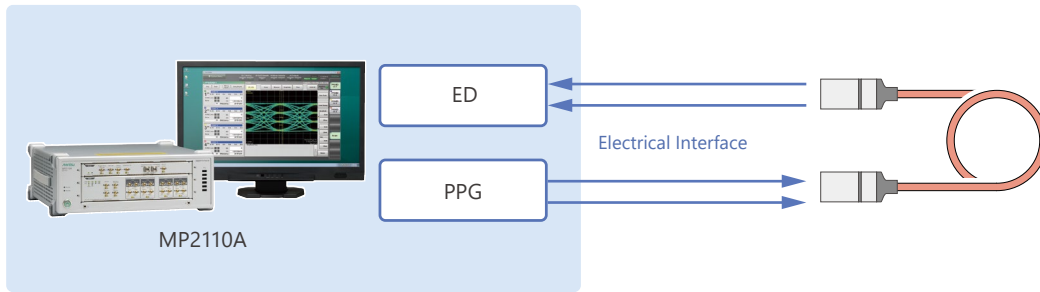

Required Test Items

- 4ch Simultaneous BER Measurement (Crosstalk Test)
- Differential Electrical Signal Eye Pattern Analysis
- Differential Electrical Signal Jitter Analysis

NRZ/PAM4 Differential Electrical Signal Evaluation

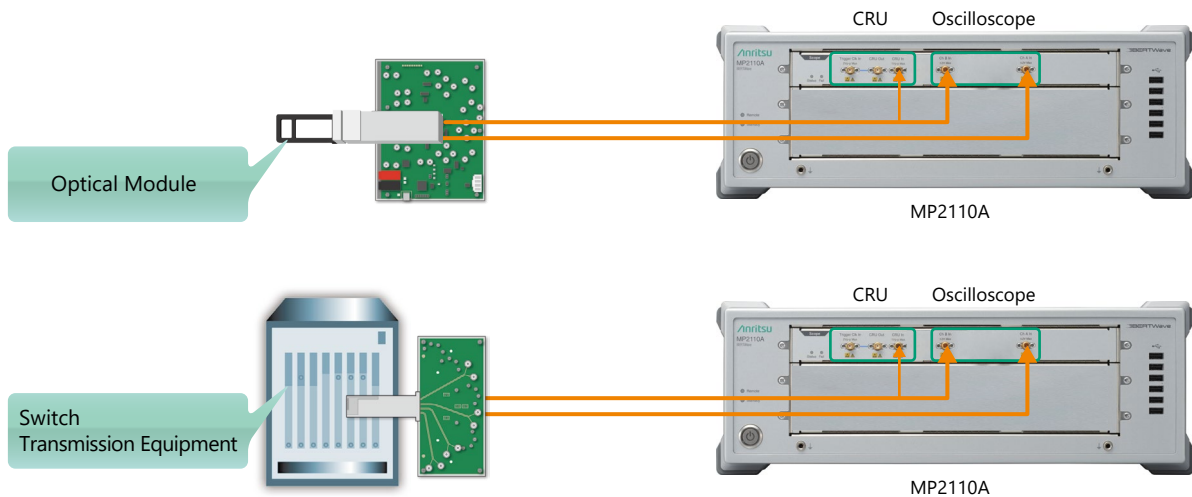

The Eye pattern of differential electrical signals can be analyzed using the Differential Electrical Channel Oscilloscope (Option x21) and Signal Processing Option (Option x98).

- A standards-compliant band filter and equalizer, such as CTLE, can be applied.
- The measurement system, such as cables, can be calibrated using the De-embedding function.

Additionally, installing the Clock Recovery Unit (CRU, Option x54) eliminates the need to provide a trigger signal.

MP2110A Specifications

Common

Remote Interfaces	Ethernet, GPIB (Option x02)	
Peripheral Devices	HDMI, DP++, USB 3.2 (3 ports on rear panel), USB 3.2 Type-C (1 port on rear panel), USB 2.0 (6 ports on front panel), Ethernet (3 ports, 2.5 Gbps) * Screen output requires a display with a resolution of 1280 × 800 or higher	
OS	Windows 10	
Internal Storage devices	SSD, 60 GB or more	
Power Voltage	100 VAC to 240 VAC, (100 VAC/200 VAC System Auto-switching), 50 Hz/60 Hz	
Power Consumption	≤300 VA	
Operating Temperature	+5°C to +40°C	
Storage Temperature	-20°C to +60°C	
Dimensions	422 (W) × 142.5 (H) × 389.4 (D) mm (excluding projections)	
Mass	<11 kg	
CE	EMC	2014/30/EU, EN61326-1, EN61000-3-2
	LVD	2014/35/EU, EN61010-1
	RoHS	2011/65/EU, (EU) 2015/863, EN IEC 63000:2018
UKCA	EMC	S.I. 2016 No.1091, EN 61326-1, EN61000-3-2
	LVD	S.I. 2016 No.1101, EN 61010-1
	RoHS	S.I. 2012 No.3032, EN IEC 63000:2018

BERT (shared PPG/ED)

Internal Clock	Frequency: 10 MHz Frequency Accuracy: ±10 ppm (1 hour after power-on, design guaranteed) Bit Rate Offset: ±100 ppm (common to all channels)
External Clock Input	Connector: SMA (f) Termination: 50Ω, AC coupled Amplitude: 0.2 Vp-p to 1.6 Vp-p Waveform: Square Wave or Sine Wave Division: 1/16 (at operating bit rate of 9.5 Gbit/s to 14.2 Gbit/s) 1/40 (at operating bit rate of 24.3 Gbit/s to 28.2 Gbit/s)
Clock Output	Connector: SMA (f) Termination: 50Ω, AC coupled Clock Source: Ch1/2 or Ch3/4 Division Ratio: 1/2 (at 9.5 Gbit/s to 14.2 Gbit/s operation bit rate) 1/4 (at 24.3 Gbit/s to 28.2 Gbit/s operation bit rate) Amplitude: 0.3 Vp-p to 0.5 Vp-p Duty: 50 ±10%
Sync Output	Connector: SMA (f) Division Ratio: Pattern Sync, 1/8, 1/16, 1/40 Output Level High Level (V _{OH}): -0.2 V to 0.05 V Low Level (V _{OL}): -1.2 V to -0.7 V
Number of Channels	1 (Option x11), 2 (Option x12), 4 (Option x14)
Operation Bit Rates	24.3 Gbit/s to 28.2 Gbit/s 9.5 Gbit/s to 14.2 Gbit/s (with Option x93 installed) (in 1 kbit/s steps)

MP2110A Specifications

PPG

Data Output	<p>Data Out, $\overline{\text{Data}}$ Out Independent Connector: K (f) Amplitude Setting Range: 0.1 Vp-p to 0.8 Vp-p, 10 mV steps (single-end) 0.2 Vp-p to 1.6 Vp-p, 20 mV steps (differential output) Accuracy: $\pm 0.02 \text{ V} \pm 20\%$ for settings (at 25.78125 Gbit/s) Data Crossing: 50% $\pm 10\%$ (at 25.78125 Gbit/s, 0.3 Vp-p Amplitude) Tr/Tf (20 to 80%): 15 ps (typ.), 17 ps (max.) (at 25.78125 Gbit/s, 0.3 Vp-p Amplitude) Jitter</p> <table border="1"> <thead> <tr> <th></th> <th>Typ.</th> <th>Max.</th> </tr> </thead> <tbody> <tr> <td>Jitter (rms)*1</td> <td>600 fs*3 900 fs*4</td> <td>900 fs*3 1200 fs*4</td> </tr> <tr> <td>Intrinsic RJ (rms)*2</td> <td>400 fs*3 800 fs*4</td> <td>600 fs*3 1000 fs*4</td> </tr> </tbody> </table> <p>*1: At 25.78125 Gbit/s, 0.3 Vp-p Amplitude, at 25°C $\pm 5^\circ\text{C}$ test pattern PRBS $2^{31} - 1$ *2: At 25.78125 Gbit/s, 0.3 Vp-p Amplitude, at 25°C $\pm 5^\circ\text{C}$, 1/16 Clock Pattern *3: With Option x14 installed and when measurement channel and same channel clock source selected Example: Ch1/2 selected as clock source and measuring Ch1 *4: With Option x14 installed and when measurement channel and different channel clock source selected Example: When Ch3/4 selected as clock source and measuring Ch1 Data Out/$\overline{\text{Data}}$ Out Skew: $\pm 8 \text{ ps}$: Internal (at 25.78125 Gbit/s, 0.3 Vp-p Amplitude)</p>		Typ.	Max.	Jitter (rms)*1	600 fs*3 900 fs*4	900 fs*3 1200 fs*4	Intrinsic RJ (rms)*2	400 fs*3 800 fs*4	600 fs*3 1000 fs*4
	Typ.	Max.								
Jitter (rms)*1	600 fs*3 900 fs*4	900 fs*3 1200 fs*4								
Intrinsic RJ (rms)*2	400 fs*3 800 fs*4	600 fs*3 1000 fs*4								
Data Format	NRZ									
Test Patterns	PRBS: $2^7 - 1$, $2^9 - 1$, $2^{15} - 1$, $2^{23} - 1$, $2^{31} - 1$ Auxiliary Pattern: 1/2 Clock Pattern, 1/16 Clock Pattern									
Functions	Output On/Off, Pattern Inversion, Error addition									

ED

Data Input	<p>Data, $\overline{\text{Data}}$ (Single-end, Differential Input) Connector: K (f) Termination: 50Ω, AC coupled * The DC component is terminated to GND via a 50Ω. Data Format: NRZ, Mark Ratio 50%, single-end or differential input Amplitude: 0.05 Vp-p to 0.8 Vp-p Threshold: -0.085 V to $+0.085 \text{ V}$, 1 mV steps (single-end input, with external ATT factor of 0 dB) Sensitivity: 25 mVp-p typ. (20°C to 30°C) 40 mVp-p max. (25.78125 Gbit/s bit rate, PRBS $2^{31} - 1$ test pattern, single-end, Mark Ratio 1/2, loopback connection) Jitter Tolerance: 25.78125 Gbit/s bit rate, PRBS $2^{31} - 1$ test pattern, single-end, 50 mV amplitude</p>
Clock Recovery	Built-in
Test Patterns	PRBS: $2^7 - 1$, $2^9 - 1$, $2^{15} - 1$, $2^{23} - 1$, $2^{31} - 1$, Inverted Pattern
Measurements	<p>Alarm Detection: Sync Loss (test pattern and asynchronous) Bit Error Rate Detection Error Rate: 0.0001E-18 to 1.0000E-03 Error Count: 0 to 9999999, 1.0000E07 to 9.9999E17 Regenerating Clock Detection: Input signal frequency (sampling method) History: Sync Loss, Bit Error (display reset supported)</p>
Gate Settings	<p>Measurement time: 1 second to 9 days 23 hours 59 minutes 59 seconds Gating cycle: Single/Repeat/Untimed Display update interval: Can display results during measurement (Current)</p>

MP2110A Specifications

Sampling Oscilloscope

Functions with an appended green asterisk (*) require a software option license; refer to the Selection Guide.

Option	Option x3x/x4x (25/35 GHz Optical channel)	Option x8x (60 GHz Optical channel)																													
Sampling Mode	Eye, Pulse, Coherent Eye, Fast Pattern Lock*, Advanced Jitter*	Eye, Pulse, Coherent Eye, Fast Pattern Lock*																													
	Fast Pattern Lock Mode: When Sampling Mode Coherent Eye and Test Pattern settings other than Variable (PRBS7/9/11/13/15, SSPRQ)																														
Sampling Speed (nominal)	250 ksamples/s (Eye Mode, Number of Samples 1350, 25.78125 Gbaud, 1/4 Clock, 2 UI bit count)	High-speed sampling* 1 Msamples/s when installed and 250 ksamples/s when not installed (Fast Pattern Lock mode, 106.25 Gbaud, SSPRQ, 2 UI bit count)																													
NRZ Measurement	Average Power*, Extinction Ratio*, Amplitude P-P (Vpp), OMA*, VMA*, OMA at Crossing*, VMA at Crossing*, VECF, RIN OMA* ^{*1} , TDEC* ^{*3} , One Level, Zero Level, Eye Amplitude, Eye Height, Eye Height Ratio, Crossing, SNR, Jitter P-P, Jitter RMS, Rise Time, Fall Time, Eye Width, DCD *1: Optical channel only, *2: Electrical channel only, *3: No IEEE-compliant 12.6-GHz hardware filter																														
Mask Margin Measurement	Supported Masks: Selected by filter, user created Mask Adjustment: Auto Align, user defined Margin Type: Hit Count, Hit Ratio																														
Jitter Analysis*	Eye Mode, Advanced Jitter Mode: TJ (J2, J4, J9, User Defined BER), Eye Opening, RJ RMS (d-d), DJ (d-d) Advanced Jitter Mode: RJ RMS, PJ P-P, PJ Frequency, DDJ P-P, DDPWS, DCD, ISI P-P Graph: TJ/RJ/PJ/DDJ Histogram, DDJ vs. Bit, Bathtub, PJ vs. Frequency	—																													
PAM4 Measurement*	Average Power*, Amplitude P-P (Vpp), TDECQ, Partial TDECQ, Ceq, Noise Margin, Partial Noise Margin, Outer Extinction Ratio*, Outer OMA*, Outer VMA*, RIN OMA* ^{*1} , Transition Time Rise/Fall/Slowest, Overshoot, Undershoot, Peak-to-Peak Power*, Power Excursion, Linearity, Levels 0/1/2/3, Levels P-P, Levels RMS 0/1/2/3, Level Skews 0/1/2/3, Eye Levels Upper/Middle/Lower, Eye Heights Upper/Middle/Lower, Eye Widths Upper/Middle/Lower, Eye Skews Upper/Middle/Lower *1: Optical channel only, *2: Electrical channel only																														
TDECQ Measurement	TDECQ Equalizer: Supported in Fast Pattern Lock mode, No. of Taps: 3 to 21 Target SER can be specified, Threshold Adjustment, Peak Power Hit Ratio, Multimode Fiber Emulation Filter, Histogram Spacing Adjustment																														
Embedding/De-embedding*	Measurement system calibration by loading S2P/S4P file, Supported in Fast Pattern Lock mode																														
CTLE*	Defined by text file, Supported in Fast Pattern Lock mode																														
Symbol Rate	0.1 Gbaud to 60 Gbaud	0.5 Gbaud to 120 Gbaud																													
Trigger Clock Input	Connector: SMA (f) Termination: 50Ω, AC coupled	Connector: K (f) Termination: 50Ω, AC coupled																													
	Frequency: 0.1 to 15.0 GHz Division Ratio: 1 to 99 (but 1, 2, 4, 8, 16, 32, 40, 48, 64 only in Pulse Mode and Coherent Eye Mode)	Frequency: 0.5 to 32 GHz Division Ratio: 1 to 99 (but 1, 2, 4, 8, 16, 32, 64 only in Pulse Mode and Coherent Eye Mode)																													
	Trigger clock Sensitivity: 100 mVp-p (typ.) 200 mVp-p (max.) *: Square wave input at ≤1 GHz and sine-wave input at > 1 GHz	Trigger clock Sensitivity: 100 mVp-p (typ., 12 GHz to 20 GHz) 200 mVp-p (max., <20 GHz) 450 mVp-p (max., ≥20 GHz) *: Square wave input at <12 GHz and sine-wave input at ≥12 GHz																													
	Max. Amplitude: 1.2 Vp-p Absolute Max input: 2 Vp-p	Max. Amplitude: 1.2 Vp-p Absolute Max input: 2 Vp-p																													
	RMS Jitter: <table border="1"> <thead> <tr> <th>Option</th> <th>Trigger Clock Frequency</th> <th>Typ.</th> <th>Max.</th> </tr> </thead> <tbody> <tr> <td rowspan="3">Single Channel</td> <td>0.1 GHz to <1.25 GHz</td> <td>1.0 ps</td> <td>1.5 ps</td> </tr> <tr> <td>1.25 GHz to 15 GHz</td> <td>400 fs</td> <td>1.35 ps</td> </tr> <tr> <td>2.4 GHz to 15 GHz High-accuracy trigger On*</td> <td>200 fs</td> <td>280 fs</td> </tr> <tr> <td rowspan="2">Quad Channel</td> <td>0.1 GHz to <1.25 GHz</td> <td>1.0 ps</td> <td>1.5 ps</td> </tr> <tr> <td>1.25 GHz to 15 GHz</td> <td>350 fs</td> <td>600 fs</td> </tr> </tbody> </table>	Option	Trigger Clock Frequency	Typ.	Max.	Single Channel	0.1 GHz to <1.25 GHz	1.0 ps	1.5 ps	1.25 GHz to 15 GHz	400 fs	1.35 ps	2.4 GHz to 15 GHz High-accuracy trigger On*	200 fs	280 fs	Quad Channel	0.1 GHz to <1.25 GHz	1.0 ps	1.5 ps	1.25 GHz to 15 GHz	350 fs	600 fs	RMS Jitter: <table border="1"> <thead> <tr> <th>Trigger Clock Frequency</th> <th>Typ.</th> <th>Max.</th> </tr> </thead> <tbody> <tr> <td>0.1 GHz to <2.5 GHz</td> <td>1.0 ps</td> <td>1.5 ps</td> </tr> <tr> <td>2.5 GHz to 32 GHz</td> <td>175 fs</td> <td>300 fs</td> </tr> </tbody> </table>	Trigger Clock Frequency	Typ.	Max.	0.1 GHz to <2.5 GHz	1.0 ps	1.5 ps	2.5 GHz to 32 GHz	175 fs
Option	Trigger Clock Frequency	Typ.	Max.																												
Single Channel	0.1 GHz to <1.25 GHz	1.0 ps	1.5 ps																												
	1.25 GHz to 15 GHz	400 fs	1.35 ps																												
	2.4 GHz to 15 GHz High-accuracy trigger On*	200 fs	280 fs																												
Quad Channel	0.1 GHz to <1.25 GHz	1.0 ps	1.5 ps																												
	1.25 GHz to 15 GHz	350 fs	600 fs																												
Trigger Clock Frequency	Typ.	Max.																													
0.1 GHz to <2.5 GHz	1.0 ps	1.5 ps																													
2.5 GHz to 32 GHz	175 fs	300 fs																													
*: Option x24 Precision Trigger On																															

x3x: x30/x32/x33/x35/x36/x39

x4x: x40/x42/x43/x45/x46/x49

x8x: x80/x84/x85

Single Channel: x33/x43/x35/x45/x36/x46

Dual Channel: x32/x42

Quad Channel: x30/x40/x39/x49

MP2110A Specifications

Sampling Oscilloscope Optical Channel

Option	Option x3x/x4x (25/35 GHz Optical channel)		Option x8x (60 GHz Optical channel)		
Connector	FC/PC (changeable)				
Wavelength, Fiber Coupling	Option		Fiber Input	Wavelength Range	Calibrated Wavelength
	x30/x40/x80/x84		9 μm	1260 nm to 1650 nm	1550/1310 nm
	x35/x45/x40+x61	SMF Input*1	≤62.5 μm*1	850 nm to 1650 nm	1550/1310/850 nm*2
	x32/x33/x42/x43		MMF Input	≤62.5 μm*1	800 nm to 860 nm
x36/x39/x46/x49					
*1: Compatible with 9 μm single-mode fibers and 50/62.5 μm multimode fibers *2: x40+x61 only for 850 nm					
Bandwidth (typ. No Filter)	SMF Input: 35 GHz MMF Input: 25 GHz		60 GHz		
Hardware Filter	19.34 GHz – 100 GbE/4 (25.78125 Gbit/s) 20.8 GHz – 100 GbE/4 FEC (27.7393 Gbit/s) 21 GHz – OTU4 (27.952493 Gbit/s) 21 GHz – 32GFC (28.05 Gbit/s)		None		
Digital Filter*	7.46 GHz – 9.95328 Gbaud 7.5 GHz – 10.3125 Gbaud 8.96 GHz – 26.5625 Gbaud MM TDECQ 10.35 GHz – 26.5625 Gbaud MM 11.2 GHz – 26.5625/28.9 Gbaud MM TDECQ 12.4 GHz – 28.9 Gbaud MM 12.6 GHz – 25.78125/26.5625 Gbaud TDEC 13.28125 GHz – 26.5625 Gbaud SM TDECQ 14.45 GHz – 28.9 Gbaud SM TDECQ 19.34 GHz – 25.78125/26.5625 Gbaud 26.5625 GHz – 53.125 Gbaud TDECQ 27.890625 GHz – 55.78125 Gbaud 28.333 GHz – 56.666 Gbaud 38.7 GHz – 53.125 Gbaud 39.84 GHz – 53.125 Gbaud		26.5625 GHz – 53.125 Gbaud TDECQ 27.890625 GHz – 55.78125 Gbaud 28.333 GHz – 56.666 Gbaud 39.84 GHz – 53.125 Gbaud 53.125 GHz – 106.25 Gbaud TDECQ 53.956 GHz – 107.912 Gbaud 56.25 GHz – 112.5 Gbaud 56.71875 GHz – 113.4375 Gbaud TDECQ 57.5515 GHz – 115.103 Gbaud		
Optical Noise	x3x	x30	1310 nm	OTU4 Filter	Typ. 4.8 μW, Max. 6.1 μW (Typ. 6.8 μW, Max. 8.6 μW)
			No Filter	Typ. 7.6 μW, Max. 10.6 μW (Typ. 10.8 μW, Max. 15.0 μW)	
		x32/x33 SMF Input x35	1310 nm	OTU4 Filter	Typ. 3.4 μW, Max. 4.3 μW (Typ. 4.8 μW, Max. 6.1 μW)
			No Filter	Typ. 5.4 μW, Max. 7.5 μW (Typ. 7.6 μW, Max. 10.6 μW)	
		x32/x33 MMF Input x36/x39	850 nm	OTU4 Filter	Typ. 6.7 μW, Max. 8.4 μW (Typ. 9.5 μW, Max. 11.9 μW)
			No Filter	Typ. 8.1 μW, Max. 10.5 μW (Typ. 11.4 μW, Max. 14.9 μW)	
	x4x	x40	1310 nm	OTU4 Filter	Typ. 5.8 μW, Max. 7.3 μW (Typ. 8.2 μW, Max. 10.4 μW)
			No Filter	Typ. 7.8 μW, Max. 10.6 μW (Typ. 11.0 μW, Max. 15.0 μW)	
		x40+x61 x42/x43 SMF Input x45	1310 nm	OTU4 Filter	Typ. 4.1 μW, Max. 5.2 μW (Typ. 5.8 μW, Max. 7.4 μW)
			No Filter	Typ. 5.5 μW, Max. 7.5 μW (Typ. 7.8 μW, Max. 10.6 μW)	
		x42/x43 MMF Input x46/x49	850 nm	100 GbE/4 Filter	Typ. 12.2 μW, Max. 14 μW (Typ. 17.3 μW, Max. 19.8 μW)
			No Filter	Typ. 7.0 μW, Max. 8.9 μW (Typ. 9.9 μW, Max. 12.6 μW)	
x8x	x80/x84/x85	1310 nm	53.125 GHz Digital Filter	Typ. 11.0 μW, Max. 15.8 μW	
*: Numeric values in parenthesis are values for channel B when the Option x54 Clock Recovery Unit is installed.					
Recommended Input Power (Non-Saturated Range)	1310 nm: Peak Level ≤1 mW 850 nm: Peak Level ≤2 mW		1310 nm: Peak Level ≤1 mW		
Absolute Max. Rating (Damage-free Range)	SMF Input: Average Value +5 dBm, Peak +8 dBm MMF Input: Average Value +7 dBm, Peak +10 dBm		Average Value +5 dBm, Peak +8 dBm		
Optical Return Loss (typ.)	SMF Input: -27 dB (1310 nm, SMF connection) MMF Input: -20 dB (850 nm, MMF connection)		-24 dB (1310 nm, SMF connection)		
Optical Power Meter Accuracy (typ.)	±0.6 dB (-18 to -12 dBm) ±0.35 dB (-12 to 0 dBm) ±0.55 dB (0 to +2 dBm)*				
*: At actual measurement, it is necessary to consider the uncertainty due to the optical fiber connector. *: Applicable to MMF Input or options x30/x40/x80/x84/x85					

MP2110A Specifications

Sampling Oscilloscope Electrical Channel

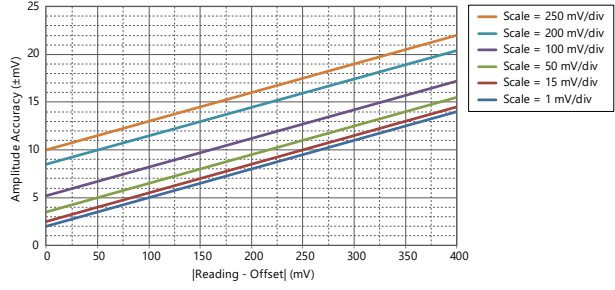
Data Input	Connector: K (f) Termination: 50Ω, DC coupled Absolute Max. Rating: ±2 V Dynamic Range: ±400 mV (Relative value of amplitude offset), Recommended input amplitude (Non-Saturated Range) ≤400 mVp-p
Amplitude Setting	Scale: 1 mV/Div to 200 mV/Div, 1 mV steps Offset: -500 mV to +500 mV, 1 mV steps
Amplitude Accuracy	± (2% of reading) ± (Amplitude Accuracy shown in the figure below) 
3-dB Bandwidth	40 GHz (typ.)
Flatness	±1 dB (10 MHz to 30 GHz, typ.)
Digital Filter*	33 GHz, 40 GHz Supported in Fast Pattern Lock mode
RMS Noise	1.5 mV (typ.), 2.5 mV (max.)

Clock Recovery

Option	Option x54 (26G SMF/MMF/Electrical Clock Recovery)	Option x55 (26G/53G SMF Clock Recovery)
Data Input	Connector: K (f), 50Ω, AC coupled * The DC component is terminated to GND via a 50Ω. Data Format: NRZ, PAM4 Bit Rate: 25.5 Gbaud to 28.2 Gbaud, 28.2 Gbaud to 28.9 Gbaud (Option x59) Input Sensitivity: 10 mVp-p (typ.)*1, *2, 20 mVp-p (max.)*2 Max. Amplitude: 800 mVp-p Absolute Maximum Input: 1 Vp-p Contiguous Zeros Tolerance: ≥500 bits at PRBS15 Zero Substitution Pattern Auto Relock	Optical Connector: FC/PC (changeable) Wavelength: 1260 nm to 1620 nm Applicable Fiber: Single Mode fiber Optical Return Loss: -30 dB (typ., 1310 nm) Data Format: NRZ, PAM4 Bit Rate: 25.5 Gbaud to 28.9 Gbaud, 51 Gbaud to 58 Gbaud Input Sensitivity: Outer OMA 100 μW (typ., 26.5625/53.125 Gbaud Open Eye (PRBS13Q, TDECQ 2.0 dB)) Outer OMA 630 μW (typ., 53.125 Gbaud Stressed Eye (SSPRQ, TDECQ 3.4 dB)) Absolute Max. Rating: +9.0 dBm (Average), +12.0 dBm (Peak) Contiguous Zeros Tolerance: ≥500 bits at PRBS15 Zero Substitution Pattern Auto Relock
Data Output	Ch B O/E Monitor Out (with built-in optical channel oscilloscope) Connector: K (f) Insertion Loss: 1.5 dBo (typ.) Conversion Gain: 60 V/W (SMF input, typ.), 33 V/W (MMF input, typ.)	Optical Data Output FC Connector (changeable) Insertion Loss: 1.5 dB (typ.), 2.3 dB (max., 1310 nm)
Recovered Clock Output	Connector: SMA (f), 50Ω, AC coupled Recovery Mode Amplitude: 480 mVp-p (typ.) Division Ratio: 1/2 Jitter: 250 fs rms (typ.)*1, *3, 400 fs rms (max.)*3 Loop Bandwidth: Select from 4 MHz, 10 MHz, bit rate/1667, Attenuation: -20 dB/dec	Connector: SMA (f), 50Ω, AC coupled Recovery Mode Amplitude: 440 mVp-p (typ.), 340 mVp-p (min.) Division Ratio: 1/4 (at 25.5 Gbaud to 28.9 Gbaud input), w 1/8 (at 51 Gbaud to 58 Gbaud input) Jitter: 200 fs rms (typ.)*1, *4, *5, 400 fs rms (typ.)*4, *5 Loop Bandwidth: Select from 4 MHz, 10 MHz, bit rate/1667, Attenuation: -20 dB/dec

*1: 25° ±5°C

*2: NRZ, at 25.78125 Gbit/s, PRBS31, 10-MHz Loop Bandwidth, using MP2110A PPG

*3: NRZ, at 25.78125/26.5625/28.05 Gbit/s, 400 ±100 mVp-p, 1/4 Clock Pattern, 10-MHz Loop Bandwidth, using MP2110A PPG

*4: 4 MHz Loop Bandwidth

*5: At 26.5625/53.125 Gbaud Clock Pattern, Outer OMA 0 dBm

MP2110A Selection Guide

The MP2110A accommodates various module options in its top and bottom slots, supporting customized performance choices at purchase. Choose your preferred options from the following list.

Scope Selections

Scope options are installed in the MP2110A top slot. There are various options with different channel number and performance. Choose one from the following table.

Option	Option x80/x84/x85 + x01 + x62*1	Option x40 + x61	Option x45	Option x42	Option x43	Option x21
Number of Electrical Channels	—	—	—	—	1	2
Number of Optical Channels	4 (x80), 2 (x84), 1 (x85)	4	1	2	1	—
Hardware Bandwidth	60 GHz	35 GHz	25/35 GHz*2			
Supported Data Rates	0.5 Gbaud to 120 Gbaud	0.1 Gbaud to 60 Gbaud	0.1 Gbaud to 60 Gbaud			
Reference Receiver	120 Gbaud	✓	—	—		
	53 Gbaud	✓	✓	✓ (at 35 GHz selection*2)		
	26 Gbaud	—	✓	✓		
Fiber Input	9 μm	62.5 μm	62.5 μm			
Wavelength Range	1260 nm to 1650 nm	850 nm to 1650 nm	800 nm to 860 nm (at 25 GHz selection*2) 850 nm to 1650 nm (at 35 GHz selection*2)			
RMS Optical Noise	850 nm	—	12.2 μW*4	7.0 μW*5 (at 25 GHz selection*2) 12.2 μW*4 (at 35 GHz selection*2)		
	1310 nm	11.0 μW*3	4.1 μW*5	4.1 μW*5		

*1: Requires x01 and x62 additions when ordering x80/x84/x85.

*2: Select 25 GHz or 35 GHz when using. 'MMF' is printed on the 25 GHz channel connector, and 'SMF' is printed on the 35 GHz channel connector.

*3: When using 53.125 GHz Digital Filter.

*4: When using 19.34 GHz Hardware Filter.

*5: When using 21 GHz Hardware Filter.

The high-accuracy trigger function (Option x24) can be added to single-channel and dual-channel scopes (but not to quad-channel scopes).

Scope Software Additions

Adding software functions to the installed scope requires addition of the appropriate option license. Options to enable functions differ according to the installed scope option. Choose from the following table.

Option	Optical Channel		Electrical Channel
	x8x	x3x/x4x*	
Fast Pattern Lock Mode Pattern Capture			x95 or x98
Digital Filter Embedding/De-embedding	x62 (required)	x95 or x98	x98
RIN OMA			—
High-Speed Sampling	x69	—	—
CTLE	—	x98	x98
PAM4 Analysis TDECQ Equalizer	x63	x95	x98 + x95
Advanced Jitter Mode NRZ Jitter Analysis	—	x96	x96

CRU Additions

There are two CRU options as follows.

- Option x54 (25.5 to 28.9G CRU): Can add to scope options x2x/x3x/x4x (but not to x8x). To extend the CRU upper limit from 28.2 Gbaud to 28.9 Gbaud, add Option x59.
- Option x55 (25.5 to 28.9/51 to 58G CRU): Install in MP2110A bottom slot. This option can be added even if there is no scope.

BERT Additions

The BERT can be installed in the MP2110A bottom slot under the following conditions.

- Scope Option x8x not installed in top slot
- CRU Option x55 not installed in bottom slot

Choose Option x11 for one channel, Option x12 for two channels, and Option x14 for four channels.

Add Option x93 when using rates from 9.5 Gbit/s to 14.2 Gbit/s.

GPIB Addition

If required, add Option x02.

MP2110A Block Diagram

Scope

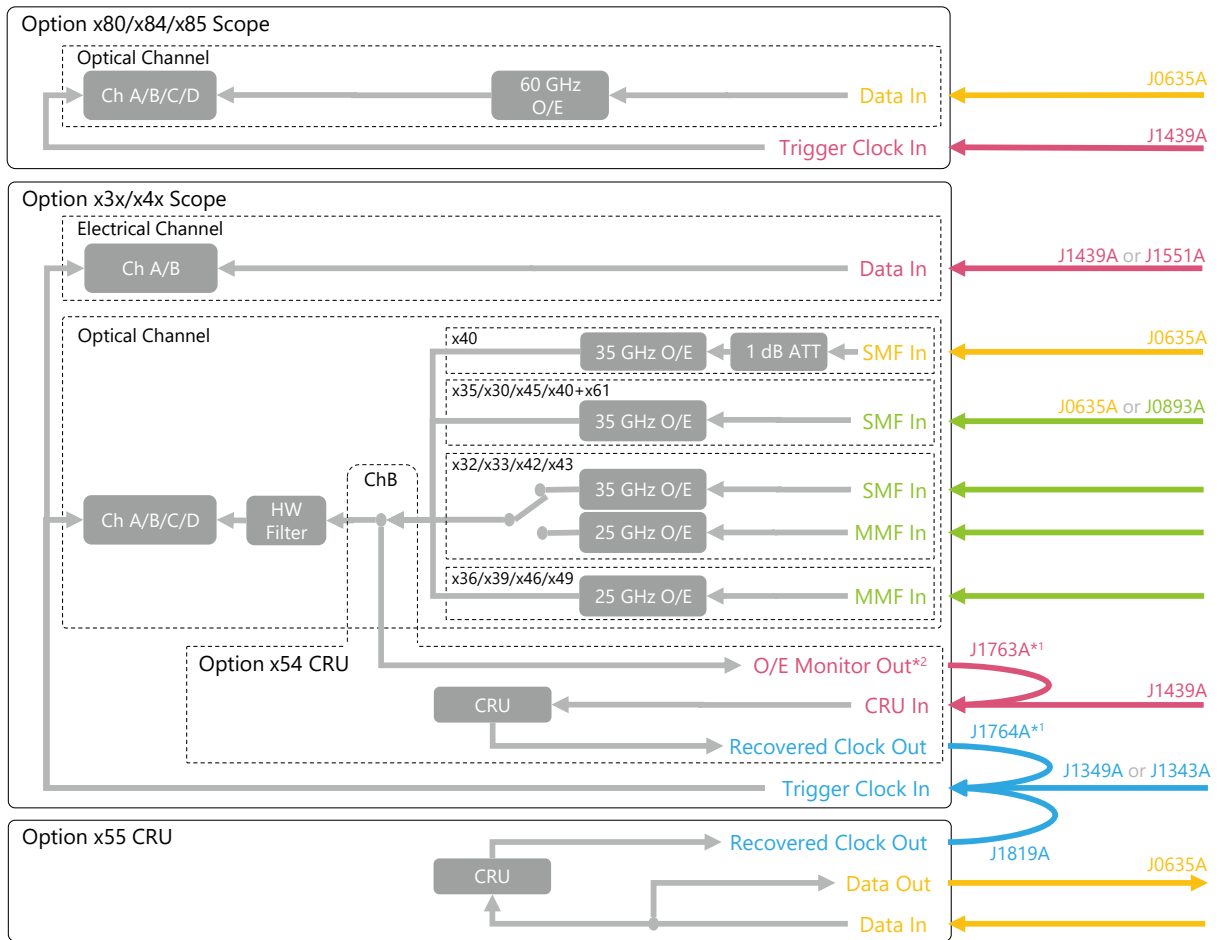

- ← Electrical cable K (2.92 mm)
- ← Electrical cable SMA
- ← Optical cable SMF
- ← Optical cable SMF or MMF

*1: Standard accessory

*2: The system recovers the clock from the optical signal input to ChB for optical channels. There is no O/E Monitor Out terminal for electrical channels. Use a Pick-off tee (J1510A) to split the signal and input it to CRU In. For differential channels, add another Pick-off tee to the other channel and attach a coaxial terminator (J1632A) to the branch.

BERT

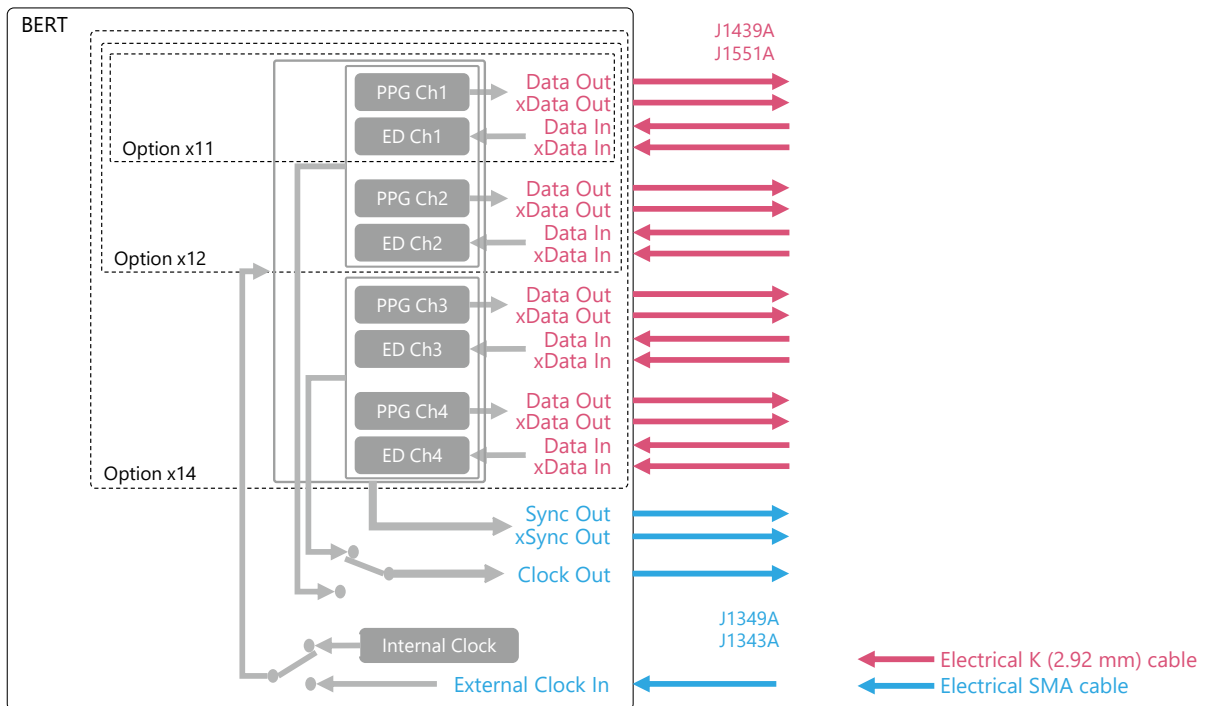

- ← Electrical K (2.92 mm) cable
- ← Electrical SMA cable

MP2110A Ordering Information

When making a contract, determine the configuration by referencing the Selection Guide (p. 21) and specify the type, model, name, and quantity. The names listed in the chart below are Order Names. The actual name of the item may differ from the Order Name.

Model/Order No.	Name
MP2110A	Main Frame BERTWave
	Options*1, *2
MP2110A-001	Cooling Performance Enhancement
MP2110A-002	GPIB
MP2110A-110	Windows10 Upgrade Retrofit*3
MP2110A-011	1ch BERT
MP2110A-111	1ch BERT Retrofit
MP2110A-012	2ch BERT
MP2110A-112	2ch BERT Retrofit
MP2110A-014	4ch BERT
MP2110A-114	4ch BERT Retrofit
MP2110A-021	Dual Electrical Scope
MP2110A-121	Dual Electrical Scope Retrofit
MP2110A-024	Precision Trigger
MP2110A-124	Precision Trigger Retrofit
MP2110A-030	Quad Optical Scope for Singlemode Baseband Flat
MP2110A-130	Quad Optical Scope for Singlemode Baseband Flat Retrofit
MP2110A-032	Dual Optical Scope Baseband Flat
MP2110A-132	Dual Optical Scope Baseband Flat Retrofit
MP2110A-033	Optical and Single-ended Electrical Scope Baseband Flat
MP2110A-133	Optical and Single-ended Electrical Scope Baseband Flat Retrofit
MP2110A-035	Optical Scope for Singlemode Baseband Flat
MP2110A-135	Optical Scope for Singlemode Baseband Flat Retrofit
MP2110A-036	Optical Scope for Multimode Baseband Flat
MP2110A-136	Optical Scope for Multimode Baseband Flat Retrofit
MP2110A-039	Quad Optical Scope for Multimode Baseband Flat
MP2110A-139	Quad Optical Scope for Multimode Baseband Flat Retrofit
MP2110A-040	Quad Optical Scope for Singlemode
MP2110A-140	Quad Optical Scope for Singlemode Retrofit
MP2110A-042	Dual Optical Scope
MP2110A-142	Dual Optical Scope Retrofit
MP2110A-043	Optical and Single-ended Electrical Scope
MP2110A-143	Optical and Single-ended Electrical Scope Retrofit
MP2110A-045	Optical Scope for Singlemode
MP2110A-145	Optical Scope for Singlemode Retrofit
MP2110A-046	Optical Scope for Multimode
MP2110A-146	Optical Scope for Multimode Retrofit
MP2110A-049	Quad Optical Scope for Multimode
MP2110A-149	Quad Optical Scope for Multimode Retrofit
MP2110A-054	Clock Recovery (Electrical/Optical)
MP2110A-154	Clock Recovery (Electrical/Optical) Retrofit
MP2110A-055	26G/53Gbaud Clock Recovery (SM Optical)
MP2110A-155	26G/53Gbaud Clock Recovery (SM Optical) Retrofit*4
MP2110A-059	25G Clock Recovery Range Extension
MP2110A-159	25G Clock Recovery Range Extension Retrofit*5
MP2110A-359	25G Clock Recovery Range Extension Retrofit*5
MP2110A-061	Low Noise and Multimode Support for Opt.040
MP2110A-062	Basic Functions
MP2110A-162	Basic Functions Retrofit
MP2110A-362	Basic Functions Retrofit
MP2110A-063	PAM4 Analysis Software for Opt.08x
MP2110A-163	PAM4 Analysis Software for Opt.08x Retrofit
MP2110A-363	PAM4 Analysis Software for Opt.08x Retrofit
MP2110A-069	Fast Sampling Mode
MP2110A-169	Fast Sampling Mode Retrofit
MP2110A-369	Fast Sampling Mode Retrofit
MP2110A-174	Quad Channel Scope Extension for Opt.084 Retrofit
MP2110A-374	Quad Channel Scope Extension for Opt.084 Retrofit
MP2110A-080	60GHz Quad Optical Scope for Singlemode
MP2110A-084	60GHz Dual Optical Scope for Singlemode
MP2110A-085	60GHz Optical Scope for Singlemode
MP2110A-093	PPG/ED Bit Rate Extension
MP2110A-193	PPG/ED Bit Rate Extension Retrofit
MP2110A-095	PAM4 Analysis Software
MP2110A-195	PAM4 Analysis Software Retrofit
MP2110A-395	PAM4 Analysis Software Retrofit*6

Model/Order No.	Name
MP2110A-096	Jitter Analysis Software
MP2110A-196	Jitter Analysis Software Retrofit
MP2110A-396	Jitter Analysis Software Retrofit
MP2110A-098	Signal Processing Software
MP2110A-198	Signal Processing Software Retrofit
MP2110A-398	Signal Processing Software Retrofit*7
	Standard Accessories (Main frame)
	Power Cord: 1
J1627A	GND Connection Cable: 1
Z1364A	MX210000A BERTWave Control Software CD-ROM: 1
	MP2110A-x11 Standard Accessories
J1632A	Terminator: 3 (Data/xData Out, xSync Out)
J1341A	Open: 5 (Ext Clk In, Clk Out, Sync Out, Data/xData In)
	MP2110A-x12 Standard Accessories
J1632A	Terminator: 5 (Data/xData Out, xSync Out)
J1341A	Open: 7 (Ext Clk In, Clk Out, Sync Out, Data/xData In)
	MP2110A-x14 Standard Accessories
J1632A	Terminator: 9 (Data/xData Out, xSync Out)
J1341A	Open: 11 (Ext Clk In, Clk Out, Sync Out, Data/xData In)
	MP2110A-x21 Standard Accessories
J1341A	Open: 3 (Trigger Clk In, Ch In)
	MP2110A-x30/x32/x39/x40/x42/x49/x80/x84 Standard Accessories
J0617B	Replaceable Optical Connector (FC-PC): 4 (Ch In)
Z0397A	FC ADAPTER CAP: 4 (Ch In)
J1341A	Open: 1 (Trigger Clk In)
	MP2110A-x33/x43 Standard Accessories
J0617B	Replaceable Optical Connector (FC-PC): 2 (Ch In)
Z0397A	FC ADAPTER CAP: 2 (Ch In)
J1341A	Open: 2 (Trigger Clk In, Ch A In)
	MP2110A-x35/x36/x45/x46/x85 Standard Accessories
J0617B	Replaceable Optical Connector (FC-PC): 1 (Ch In)
Z0397A	FC ADAPTER CAP: 1 (Ch In)
J1341A	Open: 1 (Trigger Clk In)
	MP2110A-x54 Standard Accessories
J1632A	Terminator: 1 (O/E Monitor Out) * Optical channel installed only
J1341A	Open: 2 (CRU In×1, CRU Out×1)
J1763A	U Link Coaxial Cable (K): 1 * Optical channel installed only
J1764A	U Link Coaxial Cable (SMA): 1
	MP2110A-x55 Standard Accessories
J0617B	Replaceable Optical Connector (FC-PC): 2 (Data In/Out)
Z0397A	FC ADAPTER CAP: 2 (Data In/Out)
J1341A	Open: 1 (Recovered Clock Out)
	Maintenance Service
MP2110A-ES310	3 Years Extended Warranty Service
MP2110A-ES510	5 Years Extended Warranty Service

MP2110A Ordering Information

Model/Order No.	Name
	Optional Accessories
J1341A	Open (Coaxial connector cover)
J1632A	Terminator
J1359A	Coaxial Adaptor (K-P · K-J, SMA compatible)
J1349A	Coaxial Cable (0.3 m, SMA connector)
J1343A	Coaxial Cable (1 m, SMA connector)
J1439A	Coaxial Cable (0.8 m, K connector)
J1551A	Coaxial Skew Match Cable (0.8 m, K connector)
J1763A	U Link Coaxial Cable for Option 054 (K connector)
J1764A	U Link Coaxial Cable for Option 054 (SMA connector)
J1819A	U Link Coaxial Cable for Option 055 (SMA connector)
J1510A	Pick OFF Tee
Z0397A	FC ADAPTER CAP
J1824A	Fixed Optical Attenuator (SM, 1 dB)
J1825A	Fixed Optical Attenuator (SM, 2 dB)
J1826A	Fixed Optical Attenuator (SM, 3 dB)
J1827A	Fixed Optical Attenuator (SM, 5 dB)
J0617B	Replaceable Optical Connector (FC-PC)
J0618D	Replaceable Optical Connector (ST)
J0618E	Replaceable Optical Connector (DIN)
J0619B	Replaceable Optical Connector (SC)
J0635A	FC/PC-FC/PC-1M-SM
J1139A	FC/PC-LC/PC-1M-SM
J1344A	LC/PC-LC/PC-1M-SM
J0893A	FC/PC-FC/PC-1M-GI (50/125)
Z0914A	Ferrule Cleaner
Z0915A	Replacement Reel for Ferrule Cleaner
G0306C	Video Inspection Probe
G0342A	ESD DISCHARGER
Z0306A	Wrist Strap
Z0541A	USB Mouse
B0734A	Carrying Case
B0735A	Rack Mount Kit
W3831AE	MP2110A BERTWave Operation Manual
W3773AE	BERTWave Series Remote Control Operation Manual

Refer to the selection guide (p. 21) when placing a new order.

Option numbers 0xx indicate factory installation at shipment, 1xx indicate post-delivery installation after delivery, and 3xx indicate user installation.

- *1: BERT retrofit supported when BERT not installed or to increase number of channels
- *2: Oscilloscope retrofit supported when oscilloscope not installed or when changing Option x3x and x4x, same channel configuration.
- *3: This option upgrades MP2110A units with Windows Embedded Standard 7 installed to Windows10 Enterprise LTSC.
- *4: Option x55 can be retrofitted when the BERT is not installed.
- *5: If Option x54 is already installed, option 159/359 can be ordered for serial numbers 6262201559 or larger.
- *6: Option 395 can be ordered for serial numbers 6261844875 or larger.
- *7: Option 398 can be ordered only for optical-channel configurations, or for serial numbers 6272280900 or larger.

Scope Options x2, x3x, and x4x have different reference receiver characteristics (Bessel filter approximation characteristics) for No Filter or hardware filter.

MP2110A Related Products

Signal Quality Analyzer-R MP1900A

Support 400 GbE/800 GbE and PCIe Gen4/5. All-in-One Support for Evaluating Next-Generation NRZ/PAM4 Network Interfaces and High-Speed Serial Buses

- All-in-one support for both high-speed Ethernet and PCI Express interface tests
- Easily configured and easy-to-use all-in-one 64-GBaud PAM4 BER measurement system supporting FEC analysis
- Receiver tests are supported by the built-in Protocol Awareness PCIe Link Training and LTSSM analysis functions
- High-reproducibility measurements due to high waveform quality and high input sensitivity
- Supports true signal integrity analysis, such as bit error rate measurements, Jitter Tolerance tests, etc.

The MP1900A is a high-performance BERT with excellent expandability for supporting Physical layer evaluations of these high-speed interfaces. The all-in-one design is ideal for early stage R&D evaluations of all interfaces covering ext-generation Ethernet networks to bus interconnects.



Optical Spectrum Analyzer MS9740B

600 nm to 1750 nm

Faster measurement speed shortens measurement time and improves production efficiency

- Faster measurement speed of <math><0.2\text{ s}/5\text{ nm}</math> reduces total analysis time for active optical devices
- Built-in applications for evaluating active optical devices
- Built-in Fast mode cuts measurement time by 50% for better production efficiency to predecessor MS9740A using 200 Hz or 1 kHz bandwidth
- Excellent cost performance
- >58 dB dynamic range (0.4 nm from peak wavelength)
- 30 pm minimum resolution
- Low power consumption (100 VA), light weight (15 kg max.)

The MS9740B reduces production costs by shortening active optical device evaluation times and supporting efficient analysis applications.

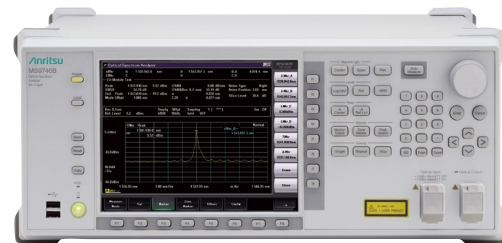

• **United States**

Anritsu Americas Sales Company

490 Jarvis Drive, Morgan Hill, CA 95037-2809, U.S.A.
Phone: (408)-778-2000

• **Canada**

Anritsu Electronics Ltd.

Americas Sales and Support

490 Jarvis Drive, Morgan Hill, CA 95037-2809, U.S.A.
Phone: +1-800-Anritsu (1-800-267-4878)

• **Brazil**

Anritsu Eletrônica Ltda.

Praça Amadeu Amaral, 27 - 1 Andar
01327-010 - Bela Vista - Sao Paulo - SP, Brazil
Phone: +55-11-3283-2511

• **Mexico**

Anritsu Company, S.A. de C.V.

Bldv Miguel de Cervantes Saavedra #169 Piso 1, Col. Granada
Mexico, Ciudad de Mexico, 11520, MEXICO
Phone: +52-55-4169-7104

• **United Kingdom**

Anritsu EMEA Limited

900 Capability Green, Luton, Bedfordshire, LU1 3LU, U.K.
Phone: +44-1582-433200

• **France**

Anritsu SA

12 avenue du Québec, Immeuble Goyave,
91140 VILLEBON SUR YVETTE, France
Phone: +33-1-60-92-15-50

• **Germany**

Anritsu GmbH

Nemetschek Haus, Konrad-Zuse-Platz 1,
81829 München, Germany
Phone: +49-89-442308-0

• **Italy**

Anritsu S.R.L.

Spaces Eur Arte, Viale dell'Arte 25, 00144 Roma, Italy
Phone: +39-6-509-9711

• **Sweden**

Anritsu AB

Kistagången 20 B, 2 tr, 164 40 Kista, Sweden
Phone: +46-8-534-707-00

• **Finland**

Anritsu AB

Technopolis Aviapolis, Teknobulevardi 3-5 (D208.5),
FI-01530 Vantaa, Finland
Phone: +358-20-741-8100

• **Denmark**

Anritsu A/S

c/o Regus Winghouse, Ørestads Boulevard 73, 4th floor,
2300 Copenhagen S, Denmark
Phone: +45-7211-2200

• **Austria**

Anritsu EMEA GmbH

Am Belvedere 10, A-1100 Vienna, Austria
Phone: +43-(0)1-717-28-710

• **United Arab Emirates**

Anritsu A/S

Office No. 164, Building 17, Dubai Internet City
P. O. Box – 501901, Dubai, United Arab Emirates
Phone: +971 (0) 4-2424919

• **India**

ANRITSU INDIA PRIVATE LIMITED

6th Floor, Indiqube ETA, No.38/4, Adjacent to EMC2,
Doddanekundi, Outer Ring Road, Bengaluru – 560048, India
Phone: +91-80-6728-1300
Fax: +91-80-6728-1301

• **Singapore**

ANRITSU PTE LTD

1 Jalan Kilang Timor, #07-04/06 Pacific Tech Centre
Singapore 159303
Phone: +65-6282-2400

• **Vietnam**

ANRITSU COMPANY LIMITED

16th Floor, Peakview Tower, 36 Hoang Cau Street, O Cho Dua Ward,
Hanoi, Vietnam
Phone: +84-24-3201-2730
Fax: +84-24-3201-2740

• **P.R. China (Shanghai)**

Anritsu (China) Co., Ltd.

Room 2301-2303, Tower A, New Caohejing International Business
Center No. 391 Gui Ping Road, Shanghai, 200233, P.R. China
Phone: +86-21-6237-0898

• **P.R. China (Hong Kong)**

ANRITSU COMPANY LIMITED

Unit 1302, 13th Floor, New East Ocean Center,
No.9 Science Museum Road, TsimShaTsui East,
Kowloon, Hong Kong
Phone: +852-2301-4980

• **Japan**

ANRITSU CORPORATION

8-5, Tamura-cho, Atsugi-shi, Kanagawa, 243-0016 Japan
Phone: +81-46-296-1244
Fax: +81-46-296-1239

• **Korea**

Anritsu Corporation Limited

8F, A TOWER, 20, Gwacheondaero 7-gil, Gwacheon-si,
Gyeonggi-do, 13840, Republic of Korea
Phone: +82-2-6259-7300

• **Australia**

Anritsu Pty Ltd

Unit 20, 21-35 Ricketts Road, Mount Waverley, Victoria 3149, Australia
Phone: +61-3-9558-8177

• **Taiwan**

ANRITSU COMPANY, INC.

7F., No. 316, Sec. 1, Neihu Rd., Neihu Dist., Taipei City 114663,
Taiwan
Phone: +886-2-8751-1816